

R-LX-CS-ZP Zinc Plated Countersunk Concrete Screw Anchor

Self-tapping concrete screwbolt



Approvals and Reports

- ETA 17/0806
- UKTA-22//6199



Product information

Features and benefits

- Time-efficient installation through streamlined procedure - simply drill and drive
- Completely removable with possibility of reuse
- Unique design with patented threadform ensures high performance for relatively small hole diameter
- Non-expansion functioning ensures low risk of damage to base material and makes R-LX ideal for installation near edges and adjacent anchors
- High performance in non-cracked concrete
- Different head types for any application
- Oversize head for fixtures with elongated holes
- Excellent product for temporary fixing
- Suitable for standard and reduced embedment depth
- Concrete screws can be used in earthquake-prone zones - seismic category C1 and C2

Applications

- Through-fixing
- Temporary anchorages
- Formwork support systems
- Balustrading & handrails
- Fencing & gates manufacturing and installation
- Racking systems
- Public seating
- Scaffolding

Base materials

Approved for use in:

- Cracked concrete C20/25-C50/60
- Non-cracked concrete C20/25-C50/60
- Reinforced concrete
- Unreinforced concrete

Installation guide

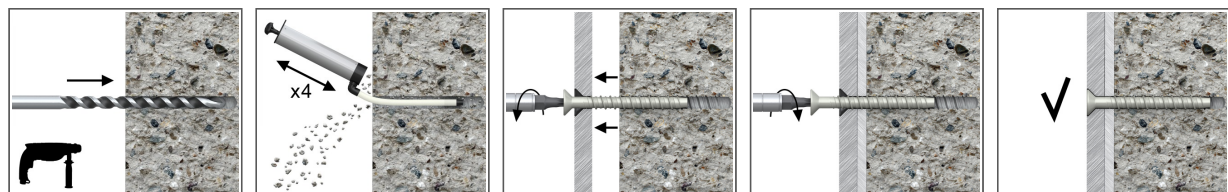

1. Drill the hole with rotary hammer drilling machine. Drill to a required depth.
2. Blow out dust at least 4 times with a hand pump.
3. Possibility of unscrewing and re-screwing.
4. Tighten to the recommended torque.
5. After installation.

Product information

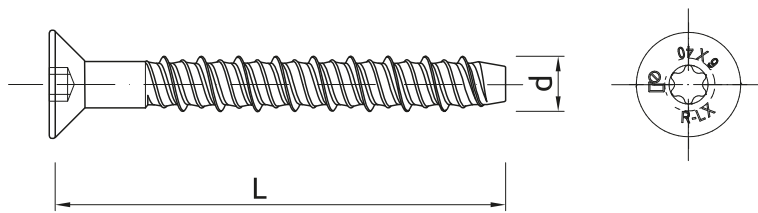

Size	Product Code	Anchor		Fixture		
		Diameter	Length	Max. thickness t_{fix} for:		Hole diameter
		d [mm]	L [mm]	$h_{nom,red}$ [mm]	$h_{nom,std}$ [mm]	d_f [mm]
8	R-LX-08X060-CS-ZP	9.9	60	10	-	12
	R-LX-08X075-CS-ZP	9.9	75	25	5	12
	R-LX-08X090-CS-ZP	9.9	90	40	20	12
	R-LX-08X100-CS-ZP	9.9	100	50	30	12
	R-LX-08X120-CS-ZP	9.9	120	70	50	12
	R-LX-08X130-CS-ZP	9.9	130	80	60	12
10	R-LX-10X060-CS-ZP	12.4	60	5	-	14
	R-LX-10X065-CS-ZP	12.4	65	10	-	14
	R-LX-10X075-CS-ZP	12.4	75	20	-	14
	R-LX-10X085-CS-ZP	12.4	85	30	-	14
	R-LX-10X090-CS-ZP	12.4	90	35	5	14
	R-LX-10X100-CS-ZP	12.4	100	45	15	14
	R-LX-10X110-CS-ZP	12.4	110	55	25	14
	R-LX-10X120-CS-ZP	12.4	120	65	35	14
	R-LX-10X130-CS-ZP	12.4	130	75	45	14
	R-LX-10X140-CS-ZP	12.4	140	85	55	14
	R-LX-10X150-CS-ZP	12.4	150	95	65	14
	R-LX-10X160-CS-ZP	12.4	160	105	75	14

Installation data

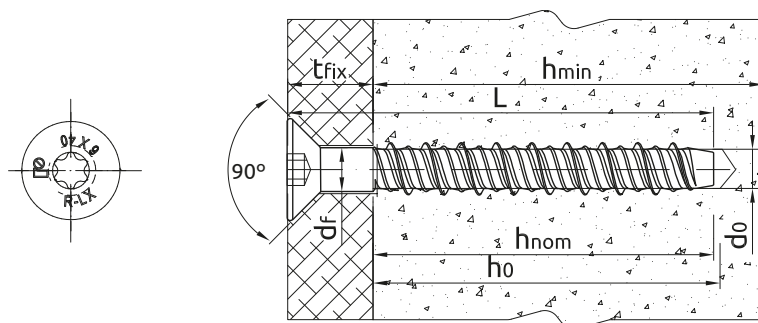

Size			8	10
Thread diameter	d	[mm]	9.9	12.4
Hole diameter in substrate	d_0	[mm]	8	10
Screw drive	-	[-]	T50	T50
Head diameter		[mm]	21.3	21.3
Max. torque for impact screw driver	$T_{imp,max}$	[Nm]	900	950

Installation data

Size			8	10
STANDARD EMBEDMENT DEPTH				
Min. hole depth in substrate	$h_{0,s}$	[mm]	80	95
Real hole depth in substrate	h_0	[mm]	$L + 10 - t_{fix}$	$L + 10 - t_{fix}$
Min. installation depth	$h_{nom,s}$	[mm]	70	85
Min. substrate thickness	$h_{min,s}$	[mm]	110	130
Min. spacing	$s_{min,s}$	[mm]	50	60
Min. edge distance	$c_{min,s}$	[mm]	50	60
REDUCED EMBEDMENT DEPTH				
Min. hole depth in substrate	$h_{0,r}$	[mm]	60	65
Real hole depth in substrate	h_0	[mm]	$L + 10 - t_{fix}$	$L + 10 - t_{fix}$
Min. installation depth	$h_{nom,r}$	[mm]	50	55
Min. substrate thickness	$h_{min,r}$	[mm]	100	100
Min. spacing	$s_{min,r}$	[mm]	50	60
Min. edge distance	$c_{min,r}$	[mm]	50	60

Mechanical properties

Size			8	10
Nominal ultimate tensile strength - tension	f_{uk}	[N/mm ²]	1200	1050
Nominal yield strength - tension	f_{yk}	[N/mm ²]	1050	950
Cross sectional area - tension	A_s	[mm ²]	50.3	78.5
Elastic section modulus	W_{el}	[mm ³]	50.3	98.1
Characteristic bending resistance	$M^0_{Rk,s}$	[Nm]	72.4	123.6
Design bending resistance	M	[Nm]	48.3	82.4

Basic performance data

Performance data for single anchor without influence of edge distance and spacing

Size		8	10
NON-CRACKED CONCRETE C20/25			
Standard embedment depth h_{nom}	[mm]	70.00	85.00
Reduced embedment depth h_{nom}	[mm]	50.00	55.00
CRACKED CONCRETE C20/25			
Standard embedment depth h_{nom}	[mm]	70.00	85.00
Reduced embedment depth h_{nom}	[mm]	50.00	55.00
MEAN ULTIMATE LOAD			
TENSION LOAD $N_{Ru,m}$			
NON-CRACKED CONCRETE C20/25			
Standard embedment depth	[kN]	26.04	35.37
Reduced embedment depth	[kN]	14.58	17.08
CRACKED CONCRETE C20/25			
Standard embedment depth	[kN]	16.10	24.89
Reduced embedment depth	[kN]	10.10	10.70
SHEAR LOAD $V_{Ru,m}$			
NON-CRACKED CONCRETE C20/25			
Standard embedment depth	[kN]	26.04	51.91
Reduced embedment depth	[kN]	14.58	17.08
CRACKED CONCRETE C20/25			
Standard embedment depth	[kN]	18.33	49.78
Reduced embedment depth	[kN]	10.26	12.02

Basic performance data

Size		8	10
CHARACTERISTIC LOAD			
TENSION LOAD N_{Rk}			
NON-CRACKED CONCRETE C20/25			
Standard embedment depth	[kN]	18.98	25.78
Reduced embedment depth	[kN]	10.63	12.45
CRACKED CONCRETE C20/25			
Standard embedment depth	[kN]	13.00	18.05
Reduced embedment depth	[kN]	7.00	8.00
SHEAR LOAD V_{Rk}			
NON-CRACKED CONCRETE C20/25			
Standard embedment depth	[kN]	18.98	41.20
Reduced embedment depth	[kN]	10.63	12.45
CRACKED CONCRETE C20/25			
Standard embedment depth	[kN]	13.29	36.09
Reduced embedment depth	[kN]	7.44	8.71
DESIGN LOAD			
TENSION LOAD N_{Rd}			
NON-CRACKED CONCRETE C20/25			
Standard embedment depth	[kN]	12.65	17.19
Reduced embedment depth	[kN]	7.08	8.30
CRACKED CONCRETE C20/25			
Standard embedment depth	[kN]	8.67	12.03
Reduced embedment depth	[kN]	4.67	5.33
SHEAR LOAD V_{Rd}			
NON-CRACKED CONCRETE C20/25			
Standard embedment depth	[kN]	12.65	27.47
Reduced embedment depth	[kN]	7.08	8.30
CRACKED CONCRETE C20/25			
Standard embedment depth	[kN]	8.86	24.06
Reduced embedment depth	[kN]	4.96	5.81

Design performance data

(-) failure is not decisive

Size			8		10	
Min. installation depth	h_{nom}	[mm]	50.00	70.00	55.00	85.00
Effective embedment depth	h_{ef}	[mm]	36.00	53.00	40.00	65.00
TENSION LOAD						
STEEL FAILURE						
Characteristic resistance	$N_{Rk,s}$	[kN]	60.40	60.40	82.40	82.40
Partial safety factor	γ_{Ms}	-	1.40	1.40	1.40	1.40
PULL-OUT FAILURE; NON-CRACKED CONCRETE C20/25						
Characteristic resistance	$N_{Rk,p}$	[kN]	-	-	-	-
PULL-OUT FAILURE; CRACKED CONCRETE C20/25						
Characteristic resistance	$N_{Rk,p}$	[kN]	7.00	13.00	8.00	-
PULL-OUT FAILURE						
Installation safety factor	γ_{inst}	-	1.00	1.00	1.00	1.00
Increasing factors for $N_{Rd,p}$ - C30/37	ψ_c	-	1.08	1.08	1.08	1.08
Increasing factors for $N_{Rd,p}$ - C40/50	ψ_c	-	1.15	1.15	1.15	1.15
Increasing factors for $N_{Rd,p}$ - C50/60	ψ_c	-	1.19	1.19	1.19	1.19
CONCRETE CONE FAILURE						
Installation safety factor	γ_{inst}	-	1.00	1.00	1.00	1.00
Factor for cracked concrete	$k_{cr,N}$	-	7.70	7.70	7.70	7.70
Factor for non-cracked concrete	$k_{ucr,N}$	-	11.00	11.00	11.00	11.00
Spacing	$s_{cr,N}$	[mm]	112.0	160.0	120.0	196.0
Edge distance	$c_{cr,N}$	[mm]	56.00	80.00	60.00	98.00
CONCRETE SPLITTING FAILURE						
Installation safety factor	γ_{inst}	-	1.00	1.00	1.00	1.00
Spacing	$s_{cr,sp}$	[mm]	112.0	160.0	136.0	222.0
Edge distance	$c_{cr,sp}$	[mm]	56.00	80.00	68.00	111.0
SHEAR LOAD						
STEEL FAILURE						
Characteristic resistance without lever arm	$V_{Rk,s}$	[kN]	30.20	30.20	41.20	41.20
Ductility factor	k_γ	-	0.80	0.80	0.80	0.80
Characteristic resistance with lever arm	$M_{Rk,s}$	[Nm]	72.40	72.40	123.6	123.6
Partial safety factor	γ_{Ms}	-	1.50	1.50	1.50	1.50
CONCRETE PRY-OUT FAILURE						
Factor	k	-	1.00	1.00	1.00	2.00
Installation safety factor	γ_{inst}	-	1.00	1.00	1.00	1.00
CONCRETE EDGE FAILURE						
Effective length of anchor	ℓ_f	[mm]	50.00	70.00	55.00	85.00
Anchor diameter	d_{nom}	[mm]	8.00	8.00	10.00	10.00
Installation safety factor	γ_{inst}	-	1.00	1.00	1.00	1.00

Design performance data

Characteristic Resistance under fire exposure in concrete C20/25 to C50/60

Size			8		10	
R (for EI) = 30 min						
Effective embedment depth	h_{ef}	[mm]	36.00	53.00	40.00	65.00
TENSION LOAD						
STEEL FAILURE						
Characteristic resistance	$N_{Rk,s}$	[kN]	0.75	0.75	1.57	1.57
PULL-OUT FAILURE						
Characteristic resistance	$N_{Rk,p}$	[kN]	1.88	3.25	2.00	4.75
SHEAR LOAD						
STEEL FAILURE						
Characteristic resistance without lever arm	$V_{Rk,s}$	[kN]	0.75	0.75	1.57	1.57
Characteristic resistance with lever arm	$M_{Rk,s}$	[Nm]	0.90	0.90	2.36	2.36
R (for EI) = 60 min						
Effective embedment depth	h_{ef}	[mm]	36.00	53.00	40.00	65.00
TENSION LOAD						
STEEL FAILURE						
Characteristic resistance	$N_{Rk,s}$	[kN]	0.65	0.65	1.18	1.18
PULL-OUT FAILURE						
Characteristic resistance	$N_{Rk,p}$	[kN]	1.88	3.25	2.00	4.75
SHEAR LOAD						
STEEL FAILURE						
Characteristic resistance without lever arm	$V_{Rk,s}$	[kN]	0.65	0.65	1.18	1.18
Characteristic resistance with lever arm	$M_{Rk,s}$	[Nm]	0.78	0.78	1.77	1.77
R (for EI) = 90 min						
Effective embedment depth	h_{ef}	[mm]	36.00	53.00	40.00	65.00
TENSION LOAD						
STEEL FAILURE						
Characteristic resistance	$N_{Rk,s}$	[kN]	0.50	0.50	1.02	1.02
PULL-OUT FAILURE						
Characteristic resistance	$N_{Rk,p}$	[kN]	1.88	3.25	2.00	4.75
SHEAR LOAD						
STEEL FAILURE						
Characteristic resistance without lever arm	$V_{Rk,s}$	[kN]	0.50	0.50	1.02	1.02
Characteristic resistance with lever arm	$M_{Rk,s}$	[Nm]	0.60	0.60	1.53	1.53
R (for EI) = 120 min						
Effective embedment depth	h_{ef}	[mm]	36.00	53.00	40.00	65.00
TENSION LOAD						
STEEL FAILURE						
Characteristic resistance	$N_{Rk,s}$	[kN]	0.40	0.40	0.79	0.79
PULL-OUT FAILURE						
Characteristic resistance	$N_{Rk,p}$	[kN]	1.50	2.60	1.60	3.80
SHEAR LOAD						
STEEL FAILURE						
Characteristic resistance without lever arm	$V_{Rk,s}$	[kN]	0.40	0.40	0.79	0.79
Characteristic resistance with lever arm	$M_{Rk,s}$	[Nm]	0.48	0.48	1.18	1.18

Design performance data

Allowable values for resistance in case of Seismic performance category C1

Size			8	10
Effective embedment depth	h_{ef}	[mm]	53.00	65.00
TENSION LOAD, STEEL FAILURE				
Characteristic resistance	$N_{Rk,s}$	[kN]	60.40	82.40
Partial safety factor	$\gamma_{MsN,seisC1}$	-	1.40	1.40
TENSION LOAD, PULL-OUT FAILURE				
Characteristic resistance	$N_{Rk,p}$	[kN]	5.40	13.50
Installation safety factor	γ_{inst}	-	1.00	1.00
SHEAR LOAD, STEEL FAILURE				
Characteristic resistance without lever arm	$V_{Rk,s}$	[kN]	15.10	27.40
Partial safety factor	$\gamma_{MsV,seisC1}$	-	1.50	1.50

Allowable values for resistance in case of Seismic performance category C2

Size			8	10
Effective embedment depth	h_{ef}	[mm]	53.00	65.00
TENSION LOAD, STEEL FAILURE				
Characteristic resistance	$N_{Rk,s}$	[kN]	60.40	82.40
Partial safety factor	$\gamma_{MsN,seisC2}$	-	1.40	1.40
TENSION LOAD, PULL-OUT FAILURE				
Characteristic resistance	$N_{Rk,p}$	[kN]	1.57	4.91
Installation safety factor	γ_{inst}	-	1.00	1.00
SHEAR LOAD, STEEL FAILURE				
Characteristic resistance without lever arm	$V_{Rk,s}$	[kN]	9.90	20.60
Partial safety factor	$\gamma_{MsV,seisC2}$	-	1.50	1.50

Product commercial data

Product Code	Anchor	Quantity [pcs]			Weight [kg]			Bar Codes
	Length [mm]	Box	Outer	Pallet	Box	Outer	Pallet	
R-LX-08X060-CS-ZP ₁₎	60	100	100	25600	2.7	2.7	728.9	5906675129327
R-LX-08X075-CS-ZP ₁₎	75	100	100	25600	3.2	3.2	849.2	5906675129334
R-LX-08X090-CS-ZP ₁₎	90	100	100	19200	3.8	3.8	757.7	5906675129341
R-LX-08X100-CS-ZP ₁₎	100	100	100	19200	4.2	4.2	830.6	5906675129358
R-LX-08X120-CS-ZP ₁₎	120	50	50	12800	2.5	2.5	662.3	5906675442471
R-LX-08X130-CS-ZP ₁₎	130	50	50	12800	2.7	2.7	712.2	5906675129365
R-LX-08X150-CS-ZP ₁₎	150	50	50	12800	3.1	3.1	812.1	5906675129372
R-LX-10X060-CS-ZP ₁₎	60	50	50	14400	2.1	2.1	647.5	5906675442426
R-LX-10X065-CS-ZP ₁₎	65	50	50	14400	2.2	2.2	672.2	5906675129389
R-LX-10X075-CS-ZP ₁₎	75	50	50	12800	2.6	2.6	690.2	5906675129396
R-LX-10X085-CS-ZP ₁₎	85	50	50	12800	2.8	2.8	757.0	5906675129402
R-LX-10X090-CS-ZP ₁₎	90	50	50	12800	3.1	3.1	813.1	5906675442433
R-LX-10X100-CS-ZP ₁₎	100	50	50	12800	3.4	3.4	892.5	5906675129419
R-LX-10X110-CS-ZP ₁₎	110	50	50	12800	3.6	3.6	947.8	5906675442440

Product commercial data

Product Code	Anchor	Quantity [pcs]			Weight [kg]			Bar Codes
	Length [mm]	Box	Outer	Pallet	Box	Outer	Pallet	
R-LX-10X120-CS-ZP ₁₎	120	25	25	6400	2.0	2.0	551.2	5906675129426
R-LX-10X130-CS-ZP ₁₎	130	25	25	9600	2.1	2.1	842.2	5906675442457
R-LX-10X140-CS-ZP ₁₎	140	25	25	9600	2.3	2.3	896.9	5906675129433
R-LX-10X150-CS-ZP ₁₎	150	20	20	7680	2.0	2.0	778.0	5906675442464
R-LX-10X160-CS-ZP ₁₎	160	20	20	7680	2.1	2.1	838.7	5906675129440

1) ETA 17/0806