



**Technical and Test Institute  
for Construction Prague**

Prosecká 811/76a  
190 00 Prague  
Czech Republic  
eota@tzus.cz



Member of



www.eota.eu

## European Technical Assessment

**ETA 17/0183  
of 27/04/2023**

**Technical Assessment Body issuing the ETA:** Technical and Test Institute  
for Construction Prague

**Trade name of the construction product**

Rawplug R-XPT Throughbolts

**Product family to which the construction  
product belongs**

Product area code: 33  
Torque controlled expansion anchor  
for use in uncracked concrete

**Manufacturer**

Rawplug S.A.  
Ul. Kwidzyńska 6  
51-416 Wrocław  
Poland

**Manufacturing plant**

Manufacturing Plant No.2  
Manufacturing Plant No.29

**This European Technical Assessment  
contains**

9 pages including 7 Annexes which form an  
integral part of this assessment

**This European Technical Assessment is  
issued in accordance with regulation  
(EU) No 305/2011, on the basis of**

EAD 330232-01-0601  
Mechanical fasteners for use in concrete

**This version replaces**

ETA 17/0183 issued on 22/11/2021

Translations of this European Technical Assessment in other languages shall fully correspond to the original issued document and should be identified as such.

Communication of this European Technical Assessment, including transmission by electronic means, shall be in full (excepted the confidential Annex(es) referred to above). However, partial reproduction may be made, with the written consent of the issuing Technical Assessment Body - Technical and Test Institute for Construction Prague. Any partial reproduction has to be identified as such.

## 1. Technical description of the product

The Rawlplug R-XPT Throughbolts are through-fixing torque-controlled expansion anchors in sizes of M8, M10, M12, M16 and M20. Each type comprises a nut, bolt, washer and expansion sleeve. The anchors are made from zinc-plated and passivated steel.

The anchor is installed in a drilled hole; tightening the nut draws the cone into the sleeve. The expansion of this sleeve applies the anchorage.

The installed anchor is shown in Annex 1.

## 2. Specification of the intended use in accordance with the applicable EAD

The performances given in Section 3 are only valid if the anchor is used in compliance with the specifications and conditions given in Annex B.

The provisions made in this European Technical Assessment are based on an assumed working life of the anchor of 50 years. The indications given on the working life cannot be interpreted as a guarantee given by the producer, but are to be regarded only as a means for choosing the products in relation to the expected economically reasonable working life of the works.

## 3. Performance of the product and references to the methods used for its assessment

### 3.1 Mechanical resistance and stability (BWR 1)

Essential characteristic	Performance
Characteristic resistance (static and quasi-static loading)	See Annex C 1 and C 2
Displacement	See Annex C 1 and C 2

### 3.2 Safety in case of fire (BWR 2)

Essential characteristic	Performance
Reaction to fire	Class A1 according to EN 13501-1
Resistance to fire	No performance assessed

## 4. Assessment and verification of constancy of performance (AVCP) system applied with reference to its legal base

According to the Decision 96/582/EC of the European Commission<sup>1</sup>, the system 1 of assessment verification of constancy of performance (see Annex V to the Regulation (EU) No 305/2011) apply.

## 5. Technical details necessary for the implementation of the AVCP system, as provided in the applicable EAD

Technical details necessary for the implementation of the AVCP system are laid down in the control plan deposited at Technical and Test Institute for Construction Prague.

Issued in Prague on 27.04.2023

By

**Ing. Jiří Studnička, Ph.D.**  
Head of the Technical Assessment Body



<sup>1</sup> Official Journal of the European Communities L 254 08.10.1996

### Rawlplug R-XPT Throughbolts - Installed anchor

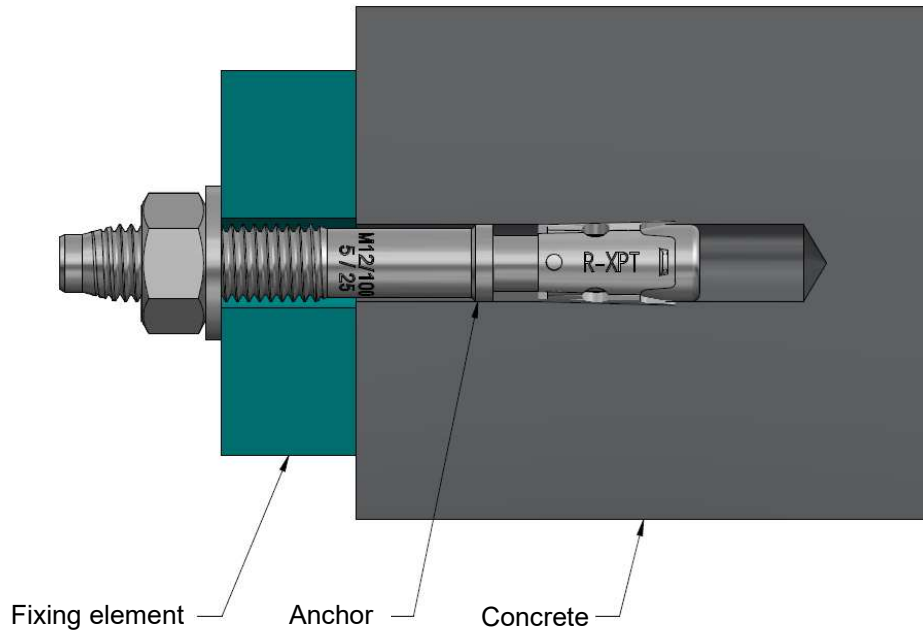

### Rawlplug R-XPT Throughbolts - components

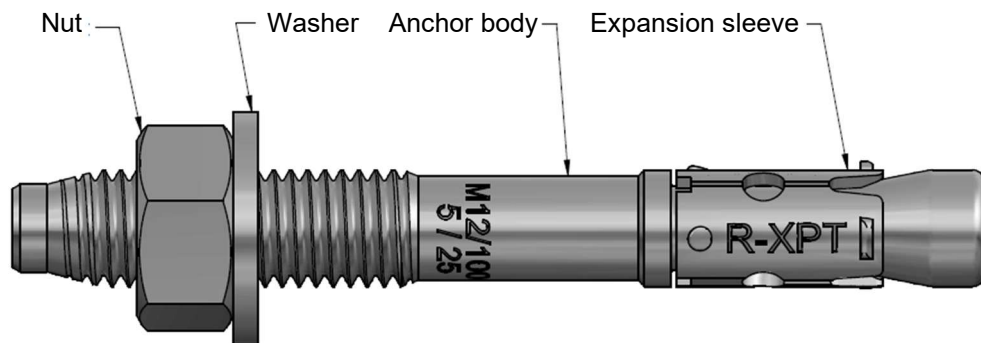

#### Rawlplug R-XPT Throughbolts

**Product description**  
Installed conditions and components

**Annex A 1**

**Table A1 - Materials**

Component	Material	Coating
Anchor body	Steel grade C17C, EN 10263-2 Rupture elongation $A_5 > 8\%$	Electroplated $\geq 5 \mu\text{m}$ and clear chromate film Cr3
Expansion sleeve	Steel grade DC03, EN 10139 M8-M12 C590 M16-M20 C490	
Hexagonal nut	according DIN 934	
Washer	according DIN 125A or DIN 9021	

**Table A2 – Marking**

<b>M8</b>																		
Bolt length [mm]	60	65	75	80	85	90	95	100	105	115	120	140	150	160				
Head marking	B	b	C	d	D	e	E	F	f	G	H	K	L	M				
$t_{\text{fix, std}}/t_{\text{fix, red}}$	-/10	-/15	10/25	15/30	20/35	25/40	30/45	35/50	40/55	50/65	55/70	75/90	85/100	95/110				
<b>M10</b>																		
Bolt length [mm]	65	80	85	90	95	115	120	130	140	150	180							
Head marking	B	D	d	e	E	G	H	J	K	L	P							
$t_{\text{fix, std}}/t_{\text{fix, red}}$	-/5	10/20	15/25	20/30	25/35	45/55	50/60	60/70	70/80	80/90	110/120							
<b>M12</b>																		
Bolt length [mm]	80	100	105	110	115	120	125	135	140	150	160	180	200	220	240	250	260	280
Head marking	D	F	f	G	g	h	H	J	K	L	M	P	R	S	T	U	V	X
$t_{\text{fix, std}}/t_{\text{fix, red}}$	-/5	5/25	10/30	15/35	20/40	25/45	30/50	40/60	45/65	55/75	65/85	85/105	105/125	125/145	145/165	155/175	165/185	185/205
<b>M16</b>																		
Bolt length [mm]	100	105	125	130	140	150	160	180	200	220	250	280	300					
Head marking	F	f	H	J	K	L	M	P	R	S	U	X	Y					
$t_{\text{fix, std}}/t_{\text{fix, red}}$	-/5	-/10	5/25	10/30	20/40	30/50	40/60	60/80	80/100	100/120	130/150	160/180	180/200					
<b>M20</b>																		
Bolt length [mm]	125	140	160	165	180	200	250	300										
Head marking	H	K	M	m	P	R	U	Y										
$t_{\text{fix, std}}/t_{\text{fix, red}}$	-/5	-/20	20/40	25/45	40/60	60/80	110/130	160/180										

**Rawlplug R-XPT Throughbolts**

**Product description**  
Materials  
Marking

**Annex A 2**

## Specifications of intended use

### Anchorage subject to:

- Static and quasi-static load.

### Base materials

- Uncracked concrete.
- Reinforced or unreinforced normal weight concrete of strength class C20/25 at minimum and C50/60 at maximum according EN 206-1:2000-12.

### Use conditions (Environmental conditions)

- Structures subject to dry internal conditions.

### Design:

- The anchorages are designed in accordance with the EN 1992-4 under the responsibility of an engineer experienced in anchorages and concrete work.
- Verifiable calculation notes and drawings are prepared taking account of the loads to be anchored. The position of the anchor is indicated on the design drawings.

### Installation:

- Anchor installation carried out by appropriately qualified personnel and under the supervision of the person responsible for technical matters of the site.
- Use of the anchor only as supplied by the manufacturer without exchanging any components of the anchor.
- Anchor installation in accordance with the manufacturer's specifications and drawings using the appropriate tools.
- Effective anchoring depth, edge distance and spacing not less than the specified values without minus tolerance.
- In case of aborted drill hole: new drilling at a minimum distance away of twice the depth of the aborted hole or smaller distance if the aborted drill hole is filled with high strength mortar and if under shear or oblique tension load it is not in the direction of load application.

**Rawlplug R-XPT Throughbolts**

**Intended use**  
Specifications

**Annex B 1**

**Table B1 - Installation parameters**

Size	Drill hole diameter $d_0$ [mm]	Max. hole diameter in fixture $d_f^{1)}$ [mm]	Standard embedment		Reduced embedment		Installation torque $T_{inst}$ [Nm]
			Min. hole depth $h_0$ [mm]	Nominal embedment depth $h_{nom}$ [mm]	Min. hole depth $h_0$ [mm]	Nominal embedment depth $h_{nom}$ [mm]	
M8	8	9	65	55	50	40	15
M10	10	12	69	59	59	49	30
M12	12	14	90	80	70	60	50
M16	16	18	110	100	90	80	100
M20	20	22	135	119	115	99	200

<sup>1)</sup> For the design of bigger clearance holes in the fixture see EN 1992-4:2018

**Table B2 - Installation parameters – Minimum spacing and edge distance**

Size			M8		M10		M12		M16		M20	
			Red <sup>1)</sup>	Std	Red <sup>1)</sup>	Std	Red	Std	Red	Std	Red	Std
Minimum thickness of concrete member	$h_{min}$	[mm]	100	100	100	100	100	136	130	170	158	198
Minimum spacing for edge distance	$s_{min}$	[mm]	45	50	55	55	100	75	100	90	125	140
	$c \geq$	[mm]	50	55	65	65	100	90	100	105	125	160
Minimum edge distance for spacing	$c_{min}$	[mm]	40	40	65	50	100	65	100	80	125	100
	$s \geq$	[mm]	100	100	55	90	100	100	100	150	125	200

<sup>1)</sup> Use restricted to anchoring statically indeterminate structural components

**Standard**

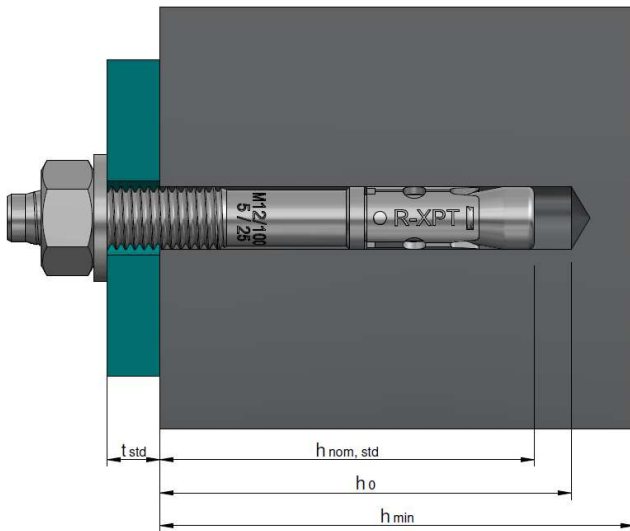

**Reduced**

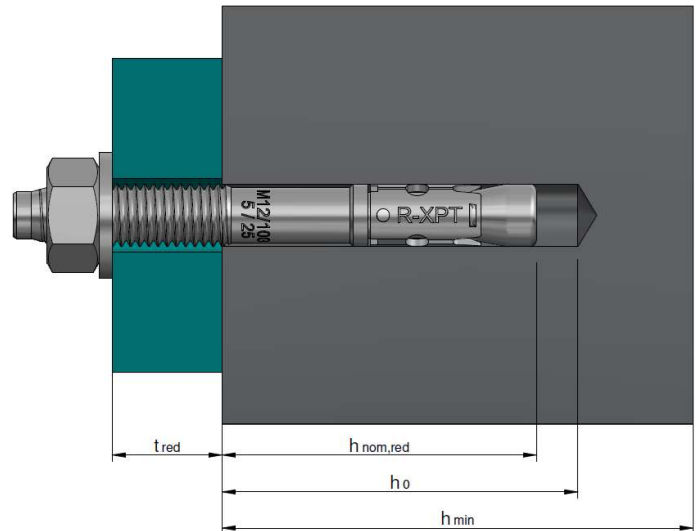

**Rawplug R-XPT Throughbolts**

**Intended use**  
Installation parameters

**Annex B 2**

## Installation instructions

1.

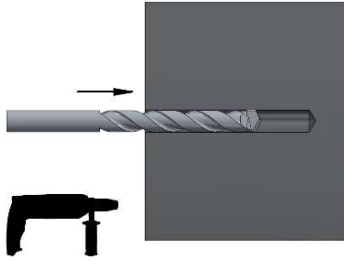

Drill a hole of required diameter and depth

2.



Clear the hole of drilling dust and debris (using blowpump or equivalent method)

3.

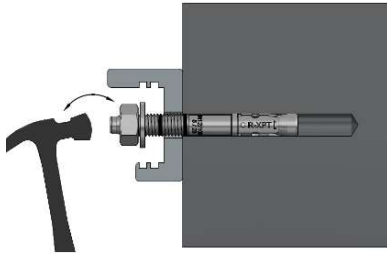

Lightly tap the throughbolt through the fixture into hole with a hammer, until fixing depth is reached

4.

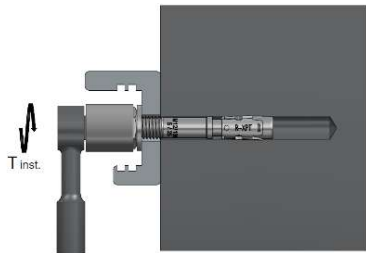

Tighten to the required torque

5.

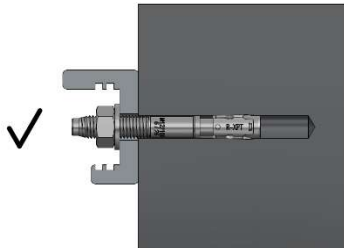

Assembled condition of anchor

**Rawlplug R-XPT Throughbolts**

**Intended use**  
Installation instructions

**Annex B 3**

**Table C1 – Characteristic resistance under tension load**

Size			M8		M10		M12		M16		M20		
			Red <sup>1)</sup>	Std	Red <sup>1)</sup>	Std	Red	Std	Red	Std	Red	Std	
<b>Steel failure</b>													
Characteristic resistance	$N_{Rk,s}$	[kN]	17,5	27,6	40,0	71,0	108,4						
Partial safety factor	$\gamma_{Ms}$	[-]	1,5	1,5	1,5	1,5	1,5						
<b>Pull-out failure</b>													
Characteristic resistance in uncracked concrete C20/25	$N_{Rk,p}$	[kN]	9	12	9	15	16	24	28	40	36	44	
Installation safety factor	$\gamma_{inst}$	[-]	1,0	1,0	1,0	1,0	1,0	1,0	1,0	1,0	1,0	1,0	
Increasing factor													
Uncracked concrete	C30/37	$\psi_c$	1,23	1,16	1,23	1,23	1,21	1,23	1,23	1,23	1,23	1,23	
	C40/50		1,43	1,28	1,43	1,43	1,39	1,43	1,43	1,43	1,43	1,43	
	C50/60		1,58	1,40	1,58	1,58	1,52	1,58	1,58	1,58	1,58	1,58	
<b>Concrete cone and splitting failure</b>													
Effective anchorage depth	$h_{ef}$	[mm]	32	47	39	49	48	68	65	85	79	99	
Factor for concrete cone failure for uncracked concrete	$k_{ucr,N}$	[-]	11,0										
Installation safety factor	$\gamma_{inst}$	[-]	1,0	1,0	1,0	1,0	1,0	1,0	1,0	1,0	1,0	1,0	
Spacing	Concrete cone failure	$s_{cr,N}$	[mm]	96	141	117	147	144	204	195	255	237	297
	Splitting failure	$s_{cr,sp}$	[mm]	160	240	200	260	250	370	360	430	410	530
Edge distance	Concrete cone failure	$c_{cr,N}$	[mm]	48	71	59	74	72	102	98	128	119	149
	Splitting failure	$c_{cr,sp}$	[mm]	80	120	100	130	125	185	180	215	205	265

<sup>1)</sup> Use restricted to anchoring statically indeterminate structural components

**Table C2 – Displacement under tension load**

Size			M8		M10		M12		M16		M20	
			Red <sup>1)</sup>	Std	Red <sup>1)</sup>	Std	Red	Std	Red	Std	Red	Std
Tension load	N	[kN]	4,2	7,1	4,3	7,1	7,8	11,4	12,3	18,4	16,4	21,0
Displacement	$\delta_{N0}$	[mm]	0,3	0,3	0,3	0,3	0,3	0,2	0,2	0,2	0,3	0,3
	$\delta_{N\infty}$	[mm]	1,7	1,7	1,7	1,7	1,7	1,7	1,7	1,7	1,7	1,7

<sup>1)</sup> Use restricted to anchoring statically indeterminate structural components

**Rawplug R-XPT Throughbolts**

**Performances**

Characteristic resistance under tension load  
Displacement under tension load

**Annex C 1**

**Table C3 – Characteristic resistance under shear load**

Steel failure without lever arm			M8		M10		M12		M16		M20	
			Red <sup>1)</sup>	Std	Red <sup>1)</sup>	Std	Red	Std	Red	Std	Red	Std
Size												
Characteristic resistance	$V_{Rk,s}^0$ [kN]		11,0		17,4		25,3		47,1		73,5	
Ductility factor	$k_7$ [-]		1		1		1		1		1	
Partial safety factor	$\gamma_{Ms}$ [-]		1,25		1,25		1,25		1,25		1,25	

Steel failure with lever arm			M8		M10		M12		M16		M20	
Characteristic resistance	$M_{Rk,s}^0$ [Nm]		22,		45		79		200		392	
Partial safety factor	$\gamma_{Ms}$ [-]		1,25		1,25		1,25		1,25		1,25	

Concrete pry-out failure			M8		M10		M12		M16		M20	
Factor	$k_8$ [-]		1,0	1,0	1,0	1,0	1,0	2,0	2,0	2,0	2,0	2,0
Installation safety factor	$\gamma_{inst}$ [-]		1,0	1,0	1,0	1,0	1,0	1,0	1,0	1,0	1,0	1,0

Concrete edge failure			M8		M10		M12		M16		M20	
Effective length of anchor	$l_f$ [mm]		32	47	39	49	48	68	65	85	79	99
Anchor diameter	$d_{nom}$ [mm]		8		10		12		16		20	
Installation safety factor	$\gamma_{inst}$ [-]		1,0	1,0	1,0	1,0	1,0	1,0	1,0	1,0	1,0	1,0

<sup>1)</sup> Use restricted to anchoring statically indeterminate structural components

**Table C4 – Displacement under shear load**

Size			M8		M10		M12		M16		M20	
			Red <sup>1)</sup>	Std	Red <sup>1)</sup>	Std	Red	Std	Red	Std	Red	Std
Shear load	$V$ [kN]		6,3	6,3	9,9	9,9	14,5	14,5	26,9	26,9	42,0	42,0
Displacement	$\delta_{V0}$ [mm]		2,8	2,8	2,9	2,9	3,8	3,8	4,7	4,7	4,6	4,6
	$\delta_{V\infty}$ [mm]		4,3	4,3	4,3	4,3	5,7	5,7	7,1	7,1	6,9	6,9

<sup>1)</sup> Use restricted to anchoring statically indeterminate structural components

<b>Rawplug R-XPT Throughbolts</b>	<b>Annex C 2</b>
<b>Performances</b>	
Characteristic resistance under shear load Displacement under shear load	