



Designated according to The Construction Products (Amendment etc.) (EU Exit) Regulations 2020

UK Technical Assessment	UKTA-0836-22/6343 of 11/11/2022
Technical Assessment Body issuing the UK Technical Assessment:	British Board of Agrément
Trade name of the construction product:	KI-10N and KI-10NS
Product family to which the construction product belongs:	Area Code 33, Nailed-in and screwed-in plastic anchors for fixing of external thermal insulation composite systems with rendering in concrete and masonry
Manufacturer:	RAWLPLUG S.A. ul. Kwidzyńska 6 PL 51-416 Wrocław Poland
Manufacturing plant(s):	Manufacturing Plant No. 3
This UK Technical Assessment contains:	20 pages including 3 annexes which form an integral part of this assessment
This UK Technical Assessment is issued in accordance with The Construction Products (Amendment etc.) (EU Exit) Regulations 2020 on the basis of:	UKAD 330196-01-0604 <i>Plastic anchors made of virgin or non-virgin material for fixing of external thermal insulation composite systems with rendering</i>

Communication of this UK Technical Assessment, including transmission by electronic means, shall be in full. However, partial reproduction may be made with the written consent of the British Board of Agrément. Any partial reproduction must be identified as such.

1 Technical description of the product

The KI-10N nailed-in plastic anchor consists of anchor sleeve with a plate manufactured from polypropylene and an accompanying specific steel nail as an expansion pin. The plastic anchor sleeve is expanded by hammering a nail, which presses the sleeve against the wall of the drilled hole.

The KI-10NS screwed-in plastic anchor consists of anchor sleeve with a plate manufactured from polypropylene and an accompanying specific steel nail with threaded end as an expansion pin. The plastic anchor sleeve is expanded by screwing in a fixing, which presses the sleeve against the wall of the drilled hole.

The KI-10N and KI-10NS anchors may in addition be combined with the plates KWL-90, KWL-110 and KWL-140.

The illustration and the description of the products are given in Annex A.

2 Specification of the intended use(s) in accordance with the applicable UK Assessment Document (hereinafter UKAD)

The performances given in clause 3 are only valid if the anchor is used in compliance with the specifications and conditions given in Annex B.

The provisions made in this UK Technical Assessment are based on an assumed working life of the anchor of 25 years. The indications given on the working life cannot be interpreted as a guarantee given by the producer or Technical Assessment Body, but are to be regarded only as a means for choosing the right products in relation to the expected economically reasonable working life of the works.

3 Performance of the product and references to the methods used for its assessment

3.1 Mechanical resistance and stability (BWR 1)

Not relevant.

3.2 Safety in case of fire (BWR 2)

Not relevant.

3.3 Health, hygiene and the environment (BWR 3)

Not relevant.

3.4 Safety and accessibility in use (BWR 4)

Essential characteristic	Performance
Characteristic resistance	Annex C1
Edge distances and spacings	Annex B2
Plate stiffness	Annex C2
Displacements	Annex C3

3.5 Protection against noise (BWR 5)

Not relevant.

3.6 Energy economy and heat retention (BWR 6)

Essential characteristic	Performance
Point thermal transmittance	Annex C2

3.7 Sustainable use of natural resources (BWR 7)

No performance assessed.

4 Assessment and verification of constancy of performance (hereinafter AVCP) system applied

4.1 System of assessment and verification of constancy of performance

According to UKAD No. 330196-01-0604 and Annex V of the Construction Products Regulation (Regulation (EU) 305/2011 as brought into UK law and amended, the system of assessment and verification of constancy of performance (AVCP) 2+ applies.

5 Technical details necessary for the implementation of the AVCP system, as provided for in the applicable UKAD

Technical details necessary for the implementation of the AVCP system are laid down in the control plan deposited with the British Board of Agrément and made available to the UK Approved Bodies involved in the conformity attestation process.

5.1 UKCA marking for the product/ system must contain the following information:

- Identification number of the Approved Body
- Name/address of the manufacturer of the product/ system
- Marking with intention of clarification of intended use
- Date of marking
- Number of certificate of constancy of performance
- UKTA number.

On behalf of the British Board of Agrément



Date of Issue: 11 November 2022

Hardy Giesler
Chief Executive Officer



British Board of Agrément,
1st Floor Building 3
Hatters Lane
Croxley Park
Watford
WD18 8YG

ANNEXES

This annex applies to the product described in the main body of the UK Technical Assessment.

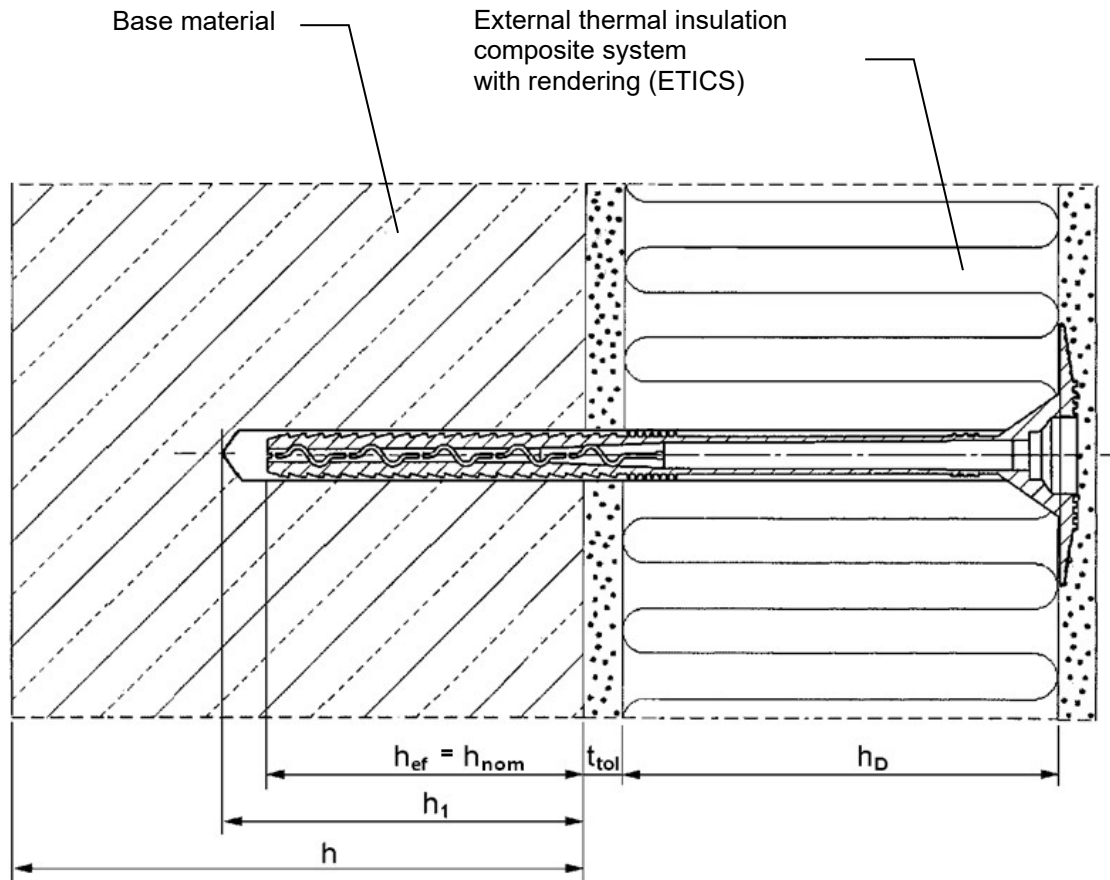

Intended Use

Fixing of external thermal insulation composite systems in concrete and in masonry

Legend

- h_{ef} = effective anchorage depth
- h_1 = depth of drill hole in base material
- h = thickness of base material
- h_D = thickness of insulation material
- t_{tol} = thickness of equalizing and/or non-load-bearing layer

KI-10N and KI-10NS

Product description
Installation conditions

Annex A 1

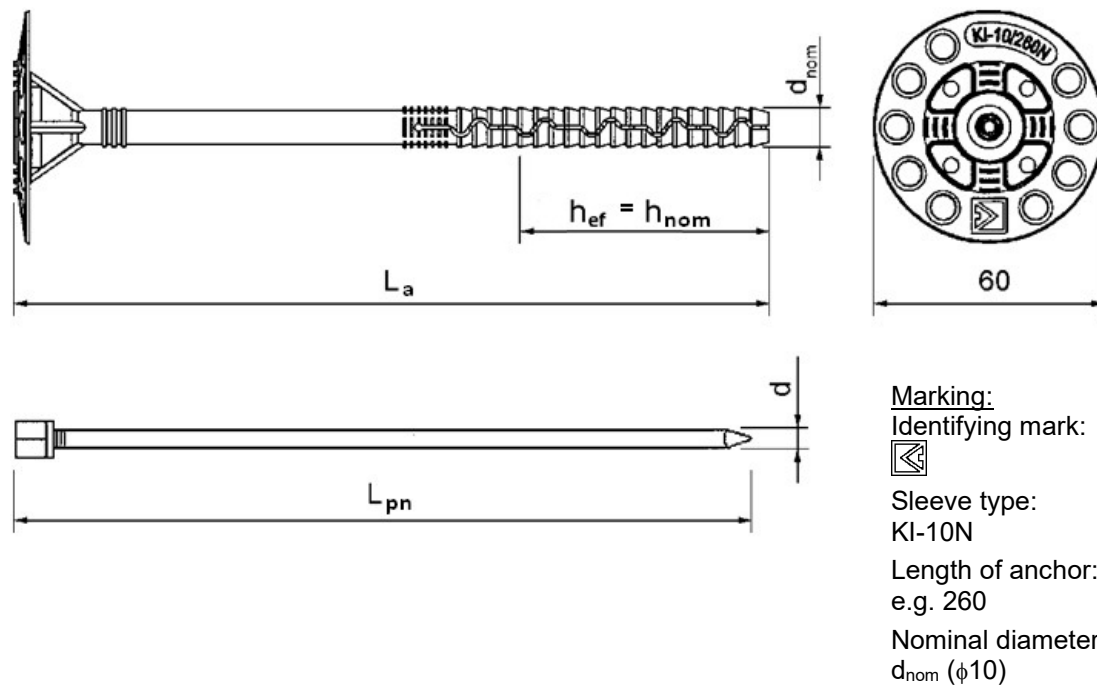

Table 1: KI-10N anchor types and dimensions [mm]

Anchor type	Anchor sleeve			Expansion pin	
	$d_{nom} \pm 0.1$	L_a	$h_{ef} = h_{nom}$	$d \pm 0.1$	$L_n \pm 2$
KI10-120N	10	120	60	4.9	120
KI10-140N	10	140	60	4.9	140
KI10-160N	10	160	60	4.9	160
KI10-180N	10	180	60	4.9	180
KI10-200N	10	200	60	4.9	200
KI10-220N	10	220	60	4.9	220
KI10-240N	10	240	60	4.9	240
KI10-260N	10	260	60	4.9	260
KI10-300N	10	300	60	4.9	300
KI10-340N	10	340	60	4.9	340

Determination of maximum thickness of insulation material: $h_D = L_a - t_{tol} - h_{ef}$

KI-10N and KI-10NS

Product description

Marking and dimensions of the anchor sleeve and expansion element of the KI-10N anchors

Annex A 2

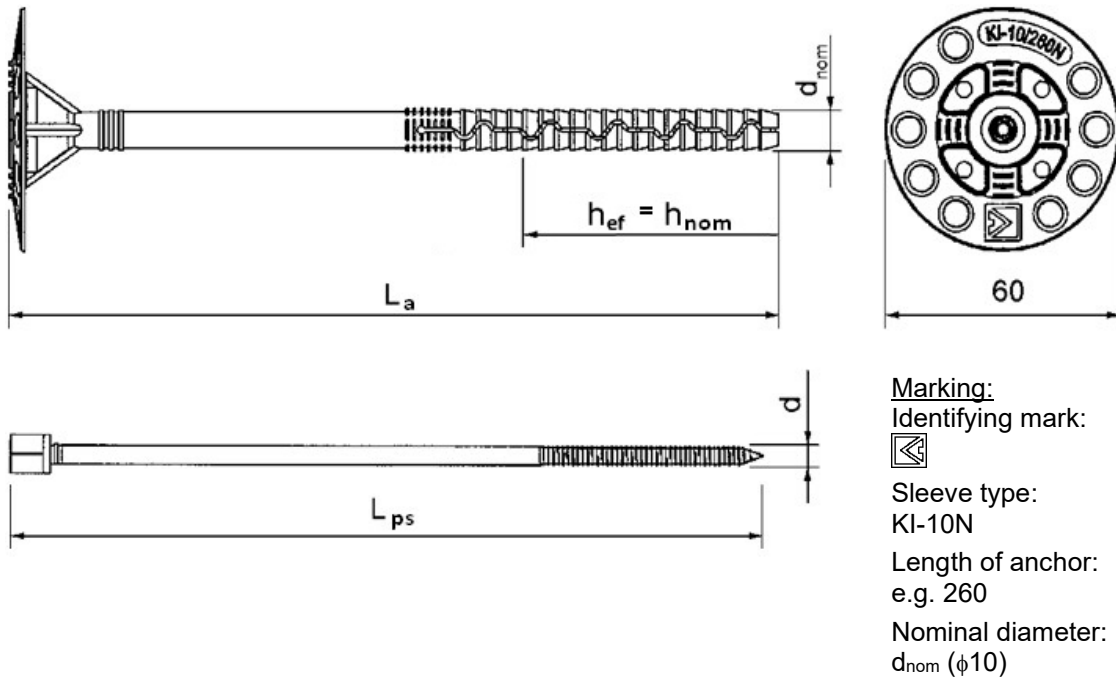

Table 2: KI-10NS anchor types and dimensions [mm]

Anchor type	Anchor sleeve			Expansion pin	
	$d_{nom} \pm 0.1$	L_a	$h_{ef} = h_{nom}$	$d \pm 0.1$	$L_s \pm 2$
KI10-140NS	10	140	60 (40) ¹	5.1	140
KI10-160NS	10	160	60 (40) ¹	5.1	160
KI10-180NS	10	180	60 (40) ¹	5.1	180
KI10-200NS	10	200	60 (40) ¹	5.1	200
KI10-220NS	10	220	60 (40) ¹	5.1	220
KI10-240NS	10	240	60 (40) ¹	5.1	240
KI10-260NS	10	260	60 (40) ¹	5.1	260
KI10-300NS	10	300	60 (40) ¹	5.1	300
KI10-340NS	10	340	60 (40) ¹	5.1	340

(1) for KI-10NS anchors in the base material category A

Determination of maximum thickness of insulation material: $h_D = L_a - t_{tol} - h_{ef}$

KI-10N and KI-10NS

Product description

Marking and dimensions of the anchor sleeve and expansion element of the KI-10NS anchors

Annex A 3

Table A3: Materials

Designation	Material
Anchor sleeve	Virgin plastic: Polypropylene, nature
Expansion pin	Carbon steel ($f_{y,k} = 190$ MPa, $f_{u,k} = 330$ MPa) galvanized ≥ 5 μm according to EN ISO 4042, with head coating of polyamide PA6, nature

KI-10N and KI-10NS

Product description
Materials

Annex A 4

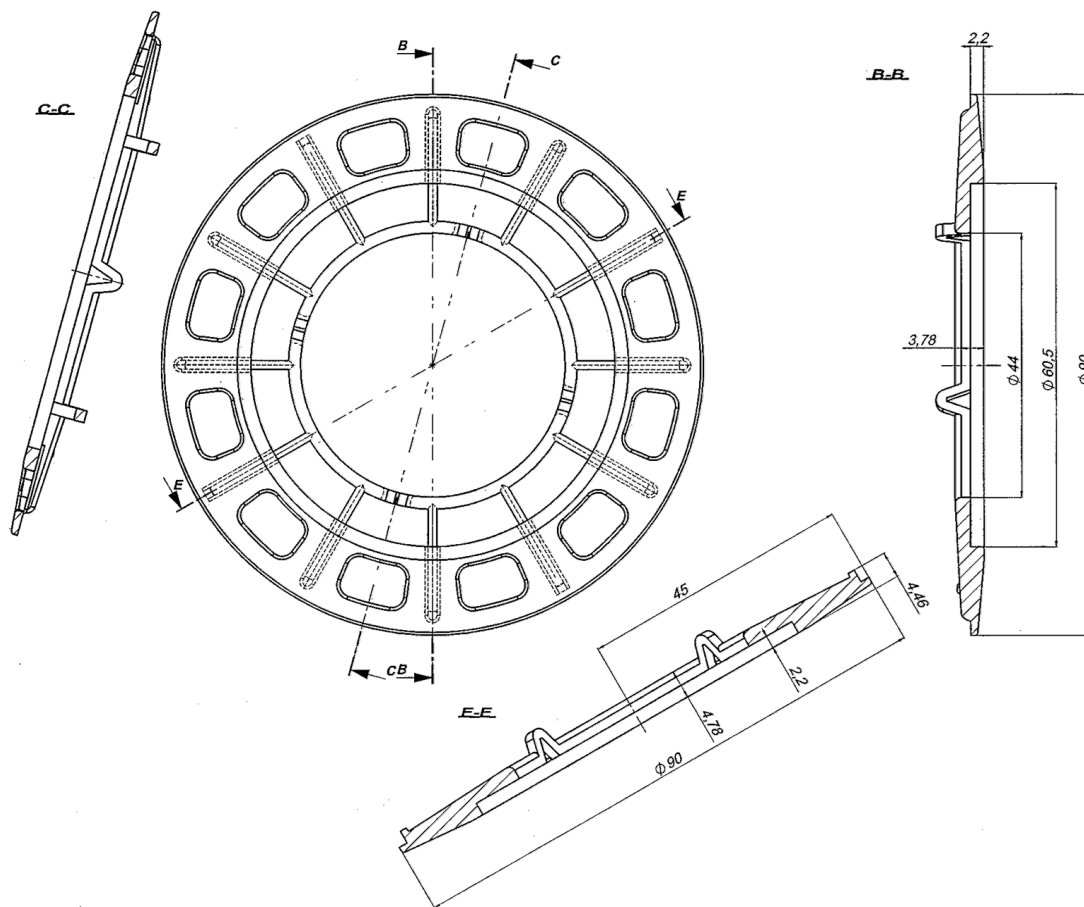

Table A4: Additional plate KWL-90

Plate type	Outer diameter [mm]	Material
KWL-90	90	Glass fibre reinforced polyamide PA6 GF 30, nature or polypropylene, nature

KI-10N and KI-10NS

Product description
Additional plate KWL-90

Annex A 5

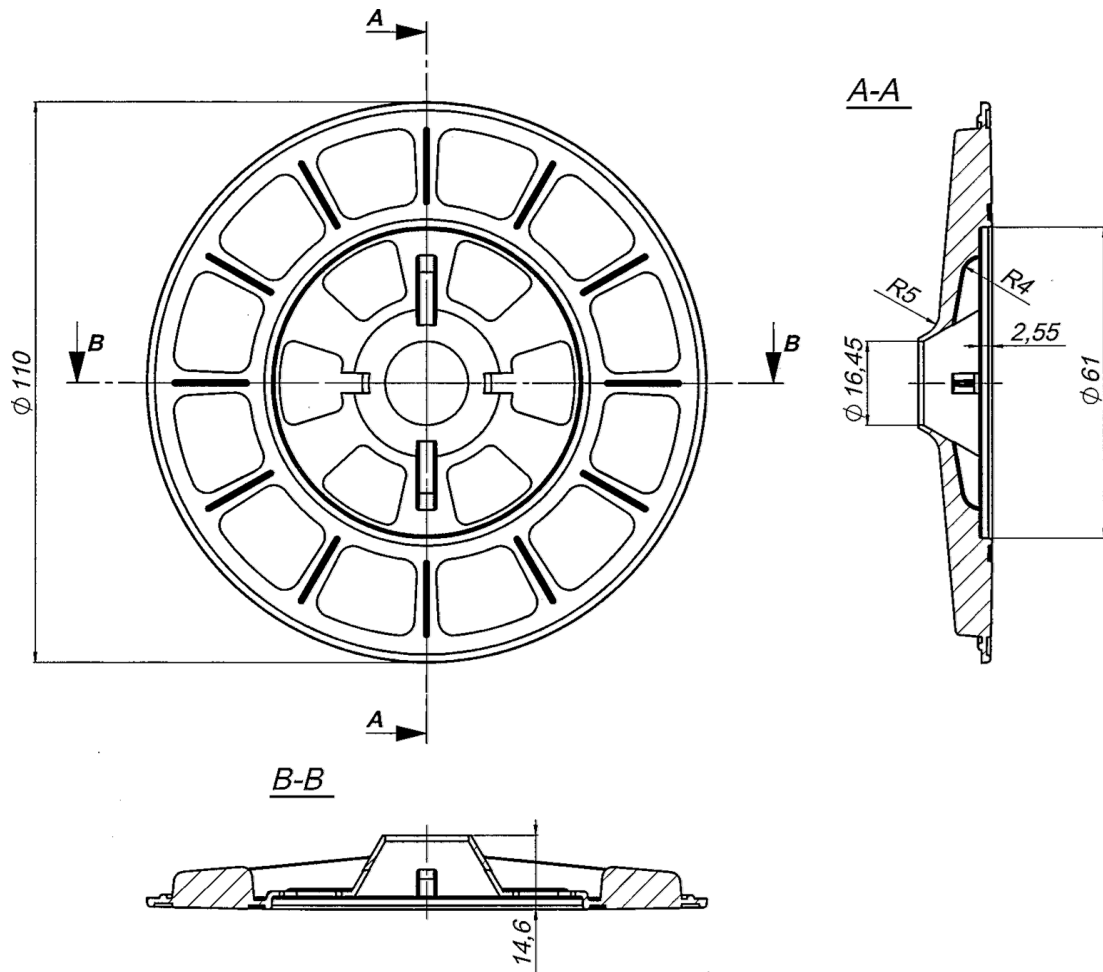

Table A5: Additional plate KWL-110

Plate type	Outer diameter [mm]	Material
KWL-110	110	Glass fibre reinforced polyamide PA6 GF 30, nature or polypropylene, nature

KI-10N and KI-10NS

Product description
Additional plate KWL-110

Annex A 6

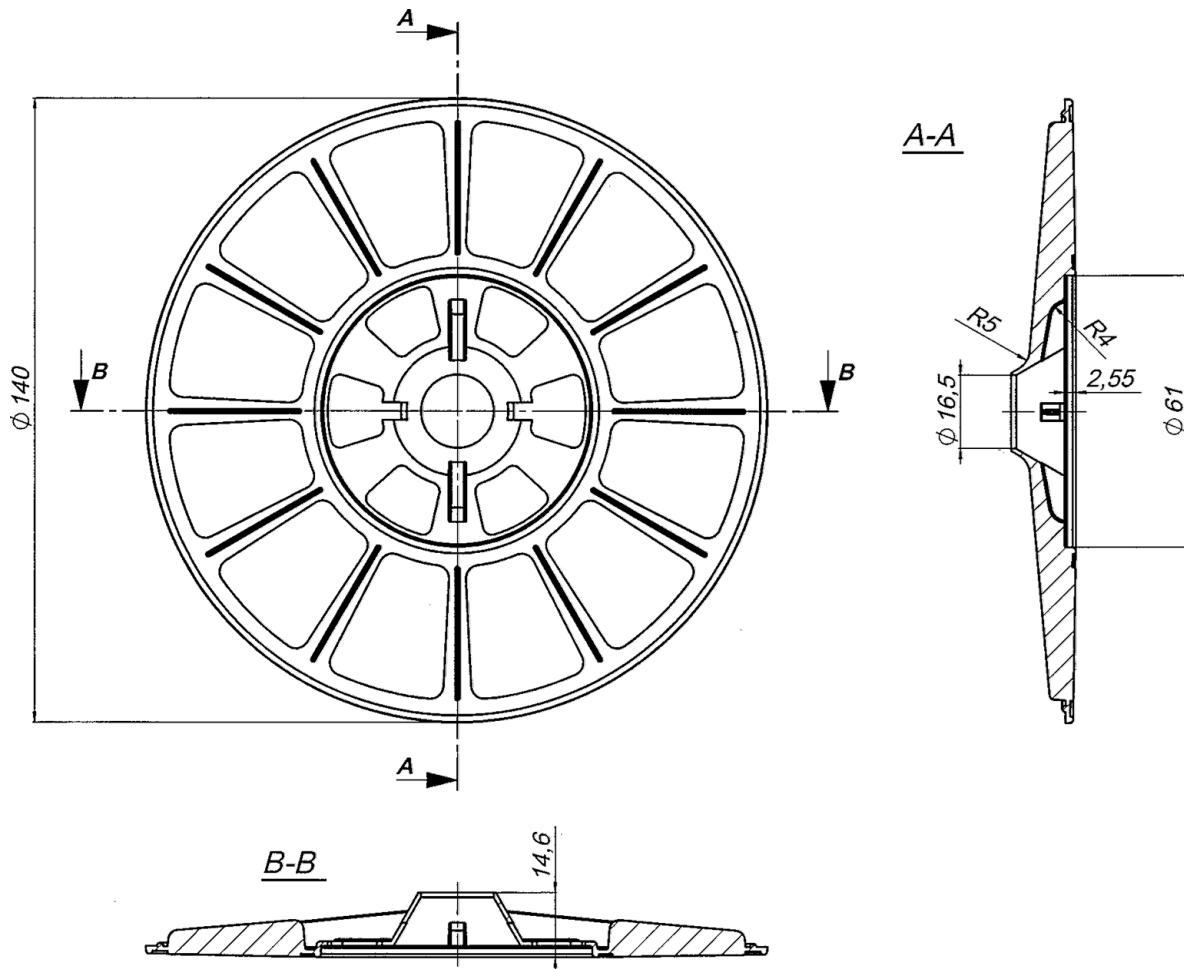

Table A6: Additional plate KWL-140

Plate type	Outer diameter [mm]	Material
KWL-140	140	Glass fibre reinforced polyamide PA6 GF 30, nature or polypropylene, nature

KI-10N and KI-10NS

Product description
Additional plate KWL-140

Annex A 7

Specification of intended use

Anchorage subject to:

- Wind suction loads.

Note: The anchor shall not be used for the transmission of dead loads of the external thermal insulation composite systems (ETICS).

Base materials:

- Normal weight concrete (use category A), according to Annex C1.
- Solid masonry (use category B), according to Annex C1.
- Hollow or perforated masonry (use category C), according to Annex C1.
- Lightweight aggregate concrete (use category D), according to Annex C1.
- Autoclaved aerated concrete (use category E), according to Annex C1.
- For other base materials of the use categories A, B, C, D or E the characteristic resistance of the anchor may be determined by job site tests according to EOTA Technical Report TR 051, edition December 2016.

Temperature range:

- 0°C to +40°C (max. short term temperature +40°C and max. long term temperature +24°C).

Design:

- The anchorages are designed under the responsibility of an engineer experienced in anchorages and masonry work with the partial safety factors $g_M = 2.0$ and $g_F = 1.5$, if there are no other national regulations.
- Verifiable calculation notes and drawings with anchor positions are prepared taking into account of the loads to be anchored.
- Fasteners are only to be used for multiple fixings of external thermal insulation composite systems (ETICS).

Installation:

- Hole shall be drilled by the drill modes according to Annex C1.
- Anchor installation shall be carried out by appropriately qualified personnel and under the supervision of the person responsible for technical matters of the site.
- Installation shall be executed in temperature from 0°C to +40°C.
- Exposure to UV due to solar radiation of the anchor not protected by rendering by the mortar shall not exceed 6 weeks.

KI-10N and KI-10NS

Intended use
Specifications

Annex B 1

Table B1: Installation characteristics

Anchor type		KI-10N and KI-10NS
Nominal diameter of drill bit	d_{nom} [mm]	10
Cutting diameter of drill bit	d_{cut} [mm]	≤ 10.45
Depth of drill hole	h_1 [mm]	$\geq (70)^{(1)}, (50)^{(2)}$
Effective anchorage depth	h_{ef} [mm]	$\geq (60)^{(1)}, (40)^{(2)}$
(1) for KI-10N and KI-10NS anchors in the base material category B, C, D, E (2) for KI-10NS anchors in the base material category A		

Table B2: Minimum thickness of base material, anchor spacing and minimum edge distance

Anchor type		KI-10N and KI-10NS
Minimum thickness of base material	h [mm]	100
Minimum spacing	s_{min} [mm]	100
Minimum edge distance	c_{min} [mm]	100

Diagram of spacing

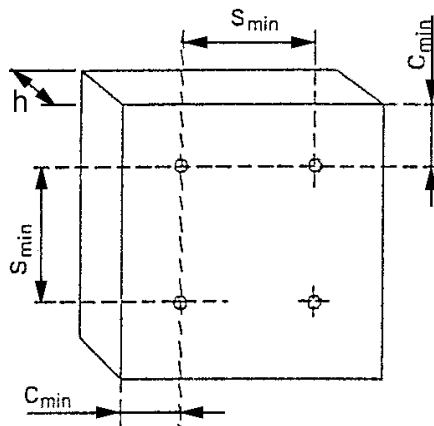

KI-10N and KI-10NS

Intended use

Installation characteristics, minimum thickness of base material, spacing and minimum edge distance

Annex B 2

Installation instruction

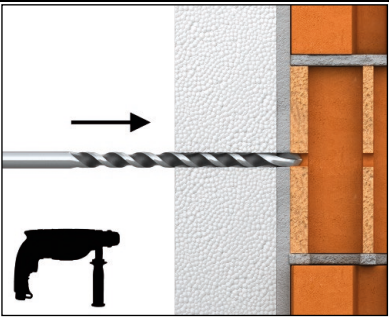
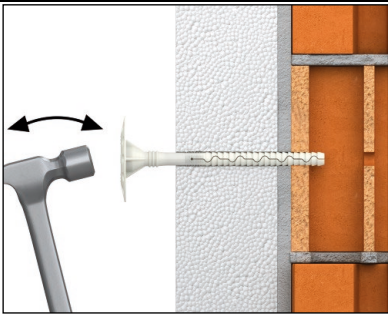
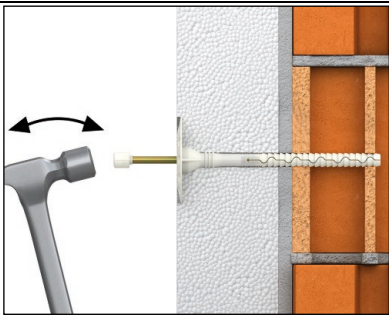
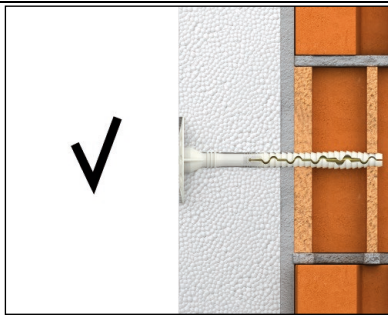
	
<p>1. Drill hole using method acc. to Annex C1</p>	<p>2. Set-in sleeve manually</p>
	
<p>3. Set expansion element by hammer blow</p>	<p>4. Correctly installed anchor</p>

KI-10N and KI-10NS

Intended use
Installation instruction of the KI-10N anchor

Annex B 3

Table C1-1: Characteristic resistance to tension loads N_{RK} in concrete and in masonry for single anchor

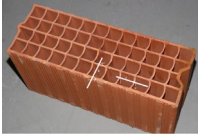
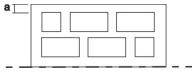
Category	Base material	Bulk density [kg/dm ³]	Compressive strength [N/mm ²]	Referring standard	Drill method	N_{RK} [kN]	
						KI-10N	KI-10NS
A	Concrete C20/25	≥ 2.25	≥ 30.0	EN 206	hammer	–	0.50
	Concrete C50/60	≥ 2.30	≥ 65.0	EN 206	hammer	–	0.60
B	Clay brick 	≥ 1.70	≥ 20.0	EN 771-1	hammer	0.75	0.90
C	Calcium silicate hollow block (KSL-R 8 DF)  $a^{(1)} = 22 \text{ mm}$	≥ 1.30	≥ 15.0	EN 771-2	rotary drilling only	0.50	0.75
	Hollowed brick (Optibrick PV acc. to EN 771-1) $a^{(1)} = 10 \text{ [mm]}$ 	≥ 0.60	≥ 7.5	EN 771-1	rotary drilling only	0.40	0.60
	Perforated ceramic brick (Hz B – 1.0 1NF 12-1)  $a^{(1)} = 13 \text{ [mm]}$ 	≥ 0.95	≥ 12.0	EN 771-1	rotary drilling only	0.60	0.90
(1) Minimum values “a”. For elements with lower value of “a” the load tests on the construction are required							

KI-10N and KI-10NS

Performances
Characteristic performance

Annex C 1

Table C1-2: Characteristic resistance to tension loads N_{Rk} in concrete and in masonry for single anchor

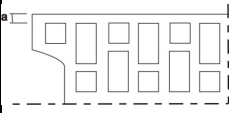
Category	Base material	Bulk density [kg/dm ³]	Compressive strength [N/mm ²]	Referring standard	Drill method	N_{Rk} [kN]	
						KI-10N	KI-10NS
C	Vertical perforated porous block (Porotherm 25 P+W)  $a^{(1)} = 10$ [mm] 	≥ 0.80	≥ 15.0	EN 771-1	rotary drilling only	0.40	0.50
D	Lightweight concrete block	≥ 1.56	≥ 20.0	EN 771-3	rotary drilling only	0.60	0.60
E	Autoclaved aerated concrete block (AAC 2)	≥ 0.35	≥ 2.0	EN 771-4	rotary drilling only	0.30	0.60
	Autoclaved aerated concrete block (AAC 5)	≥ 0.60	≥ 5.0	EN 771-4	rotary drilling only	0.90	0.75
Partial safety factor $\gamma_M^{(2)}$		2.0					
(1) Minimum values "a". For elements with lower value of "a" the load tests on the construction are required (2) Valid in absence of national regulations							

KI-10N and KI-10NS

Performances
Characteristic resistance

Annex C 1

Table C2: Point thermal transmittance according to EOTA Technical Report TR 025

Anchor type	Insulation thickness H_D [mm]	Point thermal transmittance χ [W/K]
KI-10N and KI-10NS	45-195	0.003

Table C3: Plate stiffness according to EOTA Technical Report TR 026

Anchor type	Diameter of the anchor plate d_{plate} [mm]	Load resistance of the anchor plate $N_{u,m}$ [kN]	Plate stiffness $N_{0,m}$ [kN/mm]
KI-10N and KI-10NS	60	1.23	0.5

KI-10N and KI-10NS**Performances**

Point thermal transmittance and plate stiffness

Annex C 2

Table C4-1: Displacement behaviour

Base material	Bulk density [kg/dm ³]	Compressive strength [N/mm ²]	$\frac{N_{Rk}}{3}$, [kN]		$\delta\left(\frac{N_{Rk}}{3}\right)$ [mm]	
			KI-10N	KI-10NS	KI-10N	KI-10NS
Concrete C20/25	≥ 2.25	≥ 30.0	–	0.17	–	0.32
Concrete C50/60	≥ 2.30	≥ 65.0	–	0.20	–	0.37
Clay brick 	≥ 1.70	≥ 20.0	0.25	0.30	0.91	0.33
Calcium silicate hollow block (KSL-R 8 DF)  a ⁽¹⁾ = 22 mm	≥ 1.30	≥ 15.0	0.17	0.25	0.58	0.76
Hollowed brick (Optibrick PV acc. to EN 771-1) a ⁽¹⁾ = 10 [mm] 	≥ 0.60	≥ 7.5	0.13	0.20	0.36	0.40
Perforated ceramic brick (Hz B – 1.0 1NF 12-1)  a ⁽¹⁾ = 13 [mm] 	0.95	≥ 12.0	0.20	0.30	0.79	0.44
(1) Minimum values “a”. For elements with lower value of “a” the load tests on the construction are required						

KI-10N and KI-10NS

Performances
Displacements

Annex C 3

Table C4-2: Displacement behaviour

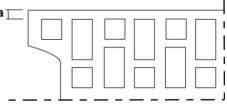
Base material	Bulk density [kg/dm ³]	Compressive strength [N/mm ²]	$\frac{N_{Rk}}{3}$, [kN]		$\delta\left(\frac{N_{Rk}}{3}\right)$ [mm]	
			KI-10N	KI-10NS	KI-10N	KI-10NS
Vertical perforated porous block (Porotherm 25 P+W)  $a^{(1)} = 10$ [mm] 	≥ 0.80	≥ 15.0	0.13	0.17	0.54	0.25
Lightweight concrete block	≥ 1.56	≥ 20.0	0.20	0.20	0.74	0.30
Autoclaved aerated concrete block (AAC 2)	≥ 0.35	≥ 2.0	0.10	0.20	0.55	0.25
Autoclaved aerated concrete block (AAC 5)	≥ 0.60	≥ 5.0	0.30	0.25	0.84	0.31
(1) Minimum values "a". For elements with lower value of "a" the load tests on the construction are required						

KI-10N and KI-10NS

Performances
Displacements

Annex C 3



British Board of Agrément,
1st Floor Building 3
Hatters Lane
Croxley Park
Watford
WD18 8YG