

## R-LX-CS-ZF Zinc Flake coated Countersunk Concrete Screw Anchor. Part 6

### Self-tapping concrete screwbolt



### Approvals and Reports

- ETA 17/0783
- UKTA-22/6346



### Product information

#### Features and benefits

- Time-efficient installation through streamlined procedure - simply drill and drive
- Completely removable with possibility of reuse
- Unique design with patented threadform ensures high performance for relatively small hole diameter and low torque level during installation even in high strength concrete
- Non-expansion functioning ensures low risk of damage to base material and makes R-LX ideal for installation near edges and adjacent anchors
- Highest performance in both cracked and non-cracked concrete
- Special zinc flake coating for increased corrosion resistance
- Different head types for any application
- Possibility of multiple use in high-strength concrete
- Allround product for any application

#### Applications

- Through-fixing
- Temporary anchorages
- Formwork support systems
- Balustrading & handrails
- Fencing & gates manufacturing and installation
- Racking systems
- Public seating
- Scaffolding

#### Base materials

##### Approved for use in:

- Cracked concrete C20/25-C50/60
- Non-cracked concrete C20/25-C50/60
- Reinforced concrete
- Unreinforced concrete

### Installation guide

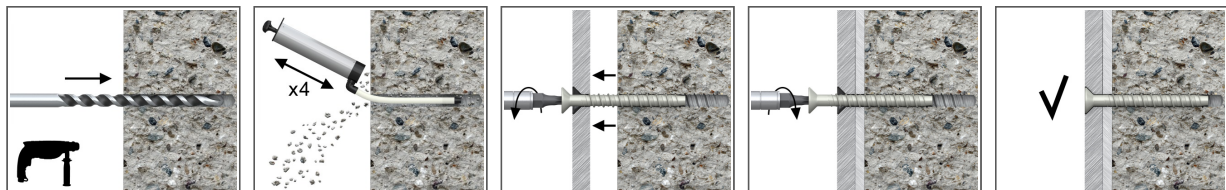

1. Drill the hole with rotary hammer drilling machine. Drill to a required depth.
2. Blow out dust at least 4 times with a hand pump.
3. Possibility of unscrewing and re-screwing.
4. Tighten to the recommended torque.
5. After installation.

Product information

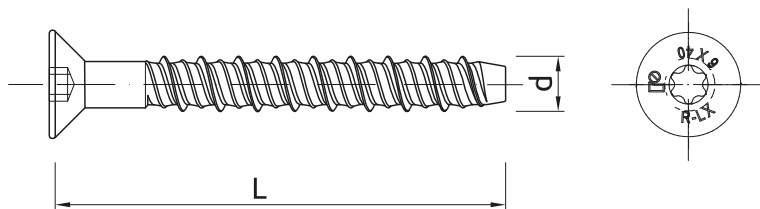

Size	Product Code	Anchor		Fixture		
		Diameter	Length	Max. thickness $t_{fix}$ for:		Hole diameter
		d [mm]	L [mm]	$h_{nom,red}$ [mm]	$h_{nom,std}$ [mm]	$d_f$ [mm]
5	R-LX-05X050-CS-ZF	6.2	50	-	7	7
	R-LX-05X075-CS-ZF	6.2	75	-	32	7
6	R-LX-06X050-CS-ZF	7.5	50	7	-	9
	R-LX-06X075-CS-ZF	7.5	75	32	20	9
	R-LX-06X100-CS-ZF	7.5	100	57	45	9
	R-LX-06X120-CS-ZF	7.5	120	77	65	9
	R-LX-06X130-CS-ZF	7.5	130	87	75	9
	R-LX-06X140-CS-ZF	7.5	140	97	85	9
	R-LX-06X150-CS-ZF	7.5	150	107	95	9
	R-LX-06X160-CS-ZF	7.5	160	117	105	9

Installation data

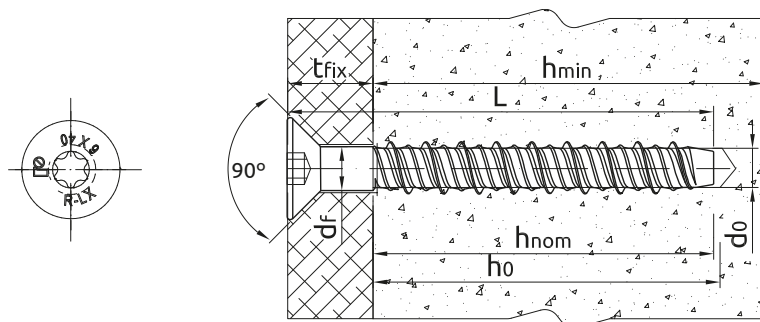

Size			5	6
Thread diameter	d	[mm]	6.2	7.5
Hole diameter in substrate	$d_0$	[mm]	5	6
Screw drive	-	[-]	T25	T40
Head diameter		[mm]	10.9	15.9
Max. torque for impact screw driver	$T_{imp,max}$	[Nm]	200	400
<b>STANDARD EMBEDMENT DEPTH</b>				
Min. hole depth in substrate	$h_{0,s}$	[mm]	50	65
Real hole depth in substrate	$h_0$	[mm]	$L + 10 - t_{fix}$	$L + 10 - t_{fix}$
Min. installation depth	$h_{nom,s}$	[mm]	43	55
Min. substrate thickness	$h_{min,s}$	[mm]	100	100
Min. spacing	$s_{min,s}$	[mm]	40	45
Min. edge distance	$c_{min,s}$	[mm]	40	45
<b>REDUCED EMBEDMENT DEPTH</b>				
Min. hole depth in substrate	$h_{0,r}$	[mm]	-	50
Real hole depth in substrate	$h_0$	[mm]	-	$L + 10 - t_{fix}$
Min. installation depth	$h_{nom,r}$	[mm]	-	43
Min. substrate thickness	$h_{min,r}$	[mm]	-	100
Min. spacing	$s_{min,r}$	[mm]	-	45
Min. edge distance	$c_{min,r}$	[mm]	-	45

## Mechanical properties

Size			5	6
Nominal ultimate tensile strength - tension	$f_{uk}$	[N/mm <sup>2</sup> ]	1300	1250
Nominal yield strength - tension	$f_{yk}$	[N/mm <sup>2</sup> ]	1150	1100
Cross sectional area - tension	$A_s$	[mm <sup>2</sup> ]	19.6	28.3
Elastic section modulus	$W_{el}$	[mm <sup>3</sup> ]	12.2	21.2
Characteristic bending resistance	$M^0_{Rk,s}$	[Nm]	19	31.8
Design bending resistance	M	[Nm]	12.7	21.2

## Basic performance data

Performance data for single anchor without influence of edge distance and spacing

Size		5	6
<b>NON-CRACKED CONCRETE C20/25</b>			
Standard embedment depth $h_{nom}$	[mm]	43.00	55.00
Reduced embedment depth $h_{nom}$	[mm]	-	35.00
<b>CRACKED CONCRETE C20/25</b>			
Standard embedment depth $h_{nom}$	[mm]	43.00	55.00
Reduced embedment depth $h_{nom}$	[mm]	-	35.00
<b>MEAN ULTIMATE LOAD</b>			
<b>TENSION LOAD <math>N_{Ru,m}</math></b>			
<b>NON-CRACKED CONCRETE C20/25</b>			
Standard embedment depth	[kN]	10.10	14.80
Reduced embedment depth	[kN]	-	12.22
<b>CRACKED CONCRETE C20/25</b>			
Standard embedment depth	[kN]	7.10	11.10
Reduced embedment depth	[kN]	-	8.60
<b>SHEAR LOAD <math>V_{Ru,m}</math></b>			
<b>NON-CRACKED CONCRETE C20/25</b>			
Standard embedment depth	[kN]	14.66	18.37
Reduced embedment depth	[kN]	-	12.22
<b>CRACKED CONCRETE C20/25</b>			
Standard embedment depth	[kN]	10.32	12.93
Reduced embedment depth	[kN]	-	8.60
<b>CHARACTERISTIC LOAD</b>			
<b>TENSION LOAD <math>N_{Rk}</math></b>			
<b>NON-CRACKED CONCRETE C20/25</b>			
Standard embedment depth	[kN]	7.00	12.00
Reduced embedment depth	[kN]	-	8.90
<b>CRACKED CONCRETE C20/25</b>			
Standard embedment depth	[kN]	4.50	7.00
Reduced embedment depth	[kN]	-	6.23
<b>SHEAR LOAD <math>V_{Rk}</math></b>			
<b>NON-CRACKED CONCRETE C20/25</b>			
Standard embedment depth	[kN]	8.90	13.39
Reduced embedment depth	[kN]	-	8.90
<b>CRACKED CONCRETE C20/25</b>			
Standard embedment depth	[kN]	6.23	9.37
Reduced embedment depth	[kN]	-	6.23

## Basic performance data

Size		5		6	
<b>DESIGN LOAD</b>					
<b>TENSION LOAD <math>N_{Rd}</math></b>					
<b>NON-CRACKED CONCRETE C20/25</b>					
Standard embedment depth	[kN]	3.89		8.00	
Reduced embedment depth	[kN]	-		5.94	
<b>CRACKED CONCRETE C20/25</b>					
Standard embedment depth	[kN]	2.50		4.67	
Reduced embedment depth	[kN]	-		4.16	
<b>SHEAR LOAD <math>V_{Rd}</math></b>					
<b>NON-CRACKED CONCRETE C20/25</b>					
Standard embedment depth	[kN]	5.94		8.93	
Reduced embedment depth	[kN]	-		5.94	
<b>CRACKED CONCRETE C20/25</b>					
Standard embedment depth	[kN]	4.16		6.25	
Reduced embedment depth	[kN]	-		4.16	

## Design performance data

(-) failure is not decisive

Size		5		6	
Min. installation depth	$h_{nom}$ [mm]	43.00	-	35.00	55.00
Effective embedment depth	$h_{ef}$ [mm]	32.00	-	24.70	42.00
<b>TENSION LOAD</b>					
<b>STEEL FAILURE</b>					
Characteristic resistance	$N_{Rk,s}$ [kN]	25.50	-	35.40	35.40
Partial safety factor	$\gamma_{Ms}$	1.40	-	1.40	1.40
<b>PULL-OUT FAILURE; NON-CRACKED CONCRETE C20/25</b>					
Characteristic resistance	$N_{Rk,p}$ [kN]	7.00	-	-	12.00
<b>PULL-OUT FAILURE; CRACKED CONCRETE C20/25</b>					
Characteristic resistance	$N_{Rk,p}$ [kN]	4.50	-	-	7.00
<b>PULL-OUT FAILURE</b>					
Installation safety factor	$\gamma_{inst}$	1.20	-	1.00	1.00
Increasing factors for $N_{Rd,p}$ - C30/37	$\psi_c$	1.08	-	1.08	1.08
Increasing factors for $N_{Rd,p}$ - C40/50	$\psi_c$	1.15	-	1.15	1.15
Increasing factors for $N_{Rd,p}$ - C50/60	$\psi_c$	1.19	-	1.19	1.19
<b>CONCRETE CONE FAILURE</b>					
Installation safety factor	$\gamma_{inst}$	1.20	-	1.00	1.00
Factor for cracked concrete	$k_{cr,N}$	7.70	-	7.70	7.70
Factor for non-cracked concrete	$k_{ucr,N}$	11.00	-	11.00	11.00
Spacing	$s_{cr,N}$ [mm]	90.00	-	90.00	126.0
Edge distance	$c_{cr,N}$ [mm]	45.00	-	45.00	63.00
<b>CONCRETE SPLITTING FAILURE</b>					
Installation safety factor	$\gamma_{inst}$	1.20	-	1.00	1.00
Spacing	$s_{cr,sp}$ [mm]	90.00	-	90.00	126.0
Edge distance	$c_{cr,sp}$ [mm]	45.00	-	45.00	63.00

## Design performance data

Size			5	6
<b>SHEAR LOAD</b>				
<b>STEEL FAILURE</b>				
Characteristic resistance without lever arm	$V_{Rk,s}$	[kN]	12.70	17.70
Ductility factor	$k_\gamma$	-	0.80	0.80
Characteristic resistance with lever arm	$M_{Rk,s}$	[Nm]	19.00	31.80
Partial safety factor	$\gamma_{Ms}$	-	1.50	1.50
<b>CONCRETE PRY-OUT FAILURE</b>				
Factor	$k$	-	1.00	1.00
Installation safety factor	$\gamma_{inst}$	-	1.00	1.00
<b>CONCRETE EDGE FAILURE</b>				
Effective length of anchor	$\ell_f$	[mm]	43.00	43.00
Anchor diameter	$d_{nom}$	[mm]	5.00	6.00
Installation safety factor	$\gamma_{inst}$	-	1.00	1.00

## Design performance data

Characteristic Resistance under fire exposure in concrete C20/25 to C50/60

Size			5		6	
<b>TENSION LOAD</b>						
Edge distance	$c_{cr}$	[mm]	-	-	-	-
Spacing	$s_{cr}$	[mm]	-	-	-	-
<b>R (for EI) = 30 min</b>						
<b>TENSION LOAD</b>						
<b>STEEL FAILURE</b>						
Characteristic resistance	$N_{Rk,s}$	[kN]	-	0.20	0.28	0.28
<b>PULL-OUT FAILURE</b>						
Characteristic resistance	$N_{Rk,p}$	[kN]	-	1.13	1.38	1.75
<b>SHEAR LOAD</b>						
<b>STEEL FAILURE</b>						
Characteristic resistance without lever arm	$V_{Rk,s}$	[kN]	-	0.20	0.28	0.28
Characteristic resistance with lever arm	$M_{Rk,s}$	[Nm]	-	0.15	0.25	0.25
Effective embedment depth	$h_{ef}$	[mm]	-	32.00	24.70	42.00
<b>R (for EI) = 60 min</b>						
<b>TENSION LOAD</b>						
<b>STEEL FAILURE</b>						
Characteristic resistance	$N_{Rk,s}$	[kN]	-	0.18	0.25	0.25
<b>PULL-OUT FAILURE</b>						
Characteristic resistance	$N_{Rk,p}$	[kN]	-	1.13	1.38	1.75
<b>SHEAR LOAD</b>						
<b>STEEL FAILURE</b>						
Characteristic resistance without lever arm	$V_{Rk,s}$	[kN]	-	0.18	0.25	0.25
Characteristic resistance with lever arm	$M_{Rk,s}$	[Nm]	-	0.13	0.23	0.23
Effective embedment depth	$h_{ef}$	[mm]	-	32.00	24.70	42.00
<b>R (for EI) = 90 min</b>						
<b>TENSION LOAD</b>						
<b>STEEL FAILURE</b>						
Characteristic resistance	$N_{Rk,s}$	[kN]	-	0.14	0.20	0.20
<b>PULL-OUT FAILURE</b>						
Characteristic resistance	$N_{Rk,p}$	[kN]	-	1.13	1.38	1.75
<b>SHEAR LOAD</b>						
<b>STEEL FAILURE</b>						
Characteristic resistance without lever arm	$V_{Rk,s}$	[kN]	-	0.14	0.20	0.20
Characteristic resistance with lever arm	$M_{Rk,s}$	[Nm]	-	0.10	0.18	0.18
Effective embedment depth	$h_{ef}$	[mm]	-	32.00	24.70	42.00
<b>R (for EI) = 120 min</b>						
<b>TENSION LOAD</b>						
<b>STEEL FAILURE</b>						
Characteristic resistance	$N_{Rk,s}$	[kN]	-	0.10	0.14	0.14
<b>PULL-OUT FAILURE</b>						
Characteristic resistance	$N_{Rk,p}$	[kN]	-	0.90	1.10	1.40
<b>SHEAR LOAD</b>						
<b>STEEL FAILURE</b>						
Characteristic resistance without lever arm	$V_{Rk,s}$	[kN]	-	0.10	0.14	0.14
Characteristic resistance with lever arm	$M_{Rk,s}$	[Nm]	-	0.07	0.13	0.13
Effective embedment depth	$h_{ef}$	[mm]	-	32.00	24.70	42.00

## Product commercial data

Product Code	Anchor	Quantity [pcs]			Weight [kg]			Bar Codes
	Length [mm]	Box	Outer	Pallet	Box	Outer	Pallet	
R-LX-05X050-CS-ZF <sub>1)</sub>	50	100	100	38400	0.89	0.89	372.9	5906675130217
R-LX-05X075-CS-ZF <sub>1)</sub>	75	100	100	38400	1.27	1.27	516.5	5906675130224
R-LX-06X050-CS-ZF <sub>1)</sub>	50	100	100	38400	1.59	1.59	640.6	5906675130231
R-LX-06X075-CS-ZF <sub>1)</sub>	75	100	100	38400	1.83	1.83	734.3	5906675130248
R-LX-06X100-CS-ZF <sub>1)</sub>	100	100	100	25600	2.4	2.4	639.8	5906675130255
R-LX-06X120-CS-ZF <sub>1)</sub>	120	100	100	25600	3.0	3.0	785.2	5906675478180
R-LX-06X130-CS-ZF <sub>1)</sub>	130	100	100	25600	3.0	3.0	799.8	5906675130262
R-LX-06X140-CS-ZF <sub>1)</sub>	140	100	100	25600	3.2	3.2	849.2	5906675478203
R-LX-06X150-CS-ZF <sub>1)</sub>	150	100	100	25600	3.4	3.4	897.8	5906675130279
R-LX-06X160-CS-ZF <sub>1)</sub>	160	100	100	25600	3.5	3.5	926.0	5906675478227

1) ETA 17/0783