



Designated according to The Construction Products (Amendment etc.) (EU Exit) Regulations 2020

UK Technical Assessment	UKTA-0836-22/6109 of 31/05/2022
Technical Assessment Body issuing the UK Technical Assessment:	British Board of Agrément
Trade name of the construction product:	Injection system R-KEX II
Product family to which the construction product belongs:	Area Code 33, Post-installed rebar connections with injection mortar
Manufacturer:	RAWLPLUG S.A. ul. Kwizyńska 6, 51-416 Wrocław, Poland
Manufacturing plant(s):	Manufacturing Plant No. 3
This UK Technical Assessment contains:	22 pages including 3 annexes which form an integral part of this assessment
This UK Technical Assessment is issued in accordance with The Construction Products (Amendment etc.) (EU Exit) Regulations 2020 on the basis of:	UKAD 330087-00-0601 "Systems for post-installed rebar connections with mortar"

Communication of this UK Technical Assessment, including transmission by electronic means, shall be in full. However, partial reproduction may be made with the written consent of the British Board of Agrément. Any partial reproduction must be identified as such.

1. Technical description of the product

This assessment covers post-installed rebar connections, involving anchoring or overlapping connection joints of steel reinforcing bars (rebars) in existing structures made of normal weight concrete, using injection mortar R-KEX II, in accordance with the regulations for reinforced concrete construction.

Reinforcing bars made of steel with diameter from 8 to 40 mm and R-KEX II injection mortar, are used for the post-installed rebar connections. The steel element is placed into a drilled hole previously filled with injection mortar and is anchored by the bond between the embedded element, injection mortar and concrete.

A description of the product is given in Annex A.

2. Specification of the intended use(s) in accordance with the applicable UK Assessment Document (hereinafter UKAD)

The performances given in Section 3 are only valid if the post-installed connections are used in compliance with the specifications and conditions given in Annex B.

The performances given in this UK Technical Assessment are based on an assumed working life of the anchor of 50 years. The indications given on the working life cannot be interpreted as a guarantee given by the producer or the Technical Assessment Body, but are to be regarded only as a means for choosing the right products in relation to the expected economically reasonable working life of the works.

3. Performance of the product and references to the methods used for its assessment

3.1 Mechanical resistance and stability (BWR 1)

The essential characteristics are detailed in the Annex C.

3.2 Safety in case of fire (BWR 2)

Not relevant.

3.3 Health, hygiene and the environment (BWR 3)

Not relevant.

3.4 Safety and accessibility in use (BWR 4)

Not relevant.

3.5 Protection against noise (BWR 5)

Not relevant.

3.6 Energy economy and heat retention (BWR 6)

Not relevant.

3.7 Sustainable use of natural resources (BWR 7)

No performance assessed.

4. Assessment and verification of constancy of performance (hereinafter AVCP) system applied

4.1 System of assessment and verification of constancy of performance

According to UKAD No. 330087-00-0601 and Annex V of the Construction Products Regulation (Regulation (EU) 305/2011 as brought into UK law and amended, the system of assessment and verification of constancy of performance (AVCP) 1 applies.

5. Technical details necessary for the implementation of the AVCP system, as provided for in the applicable UKAD

Technical details necessary for the implementation of the AVCP system are laid down in the control plan deposited with the British Board of Agrément and made available to the UK Approved Bodies involved in the conformity attestation process.

5.1 UKCA marking for the product/ system must contain the following information:

- Identification number of the Approved Body
- Name/address of the manufacturer of the product/ system
- Marking with intention of clarification of intended use
- Date of marking
- Number of certificate of constancy of performance
- UKTA number.

On behalf of the British Board of Agrément



Date of Issue: 31 May 2022

Hardy Giesler
Chief Executive Officer



British Board of Agrément,
Bucknalls Lane,
Watford,
Hertfordshire
WD25 9BA

ANNEXES

These annexes apply to the product described in the main body of the UK Technical Assessment.

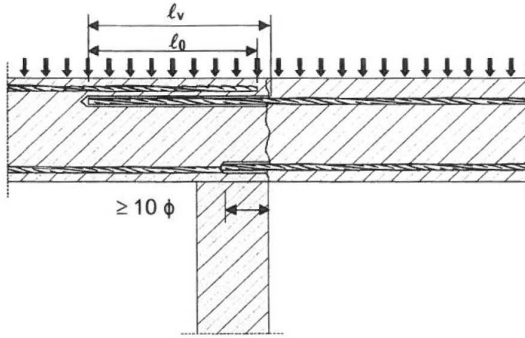

Figure A1 Overlap joint for rebar connections of slabs and beams

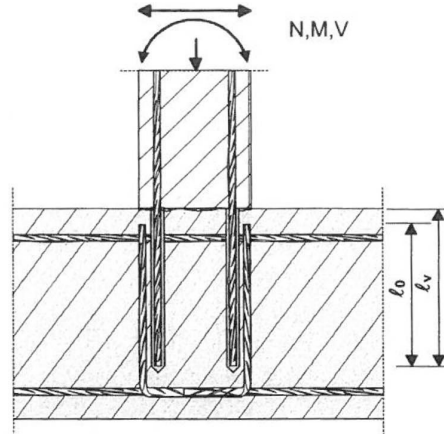

Figure A2 Overlap joint at a foundation of a column or wall where the rebar is stressed in tension

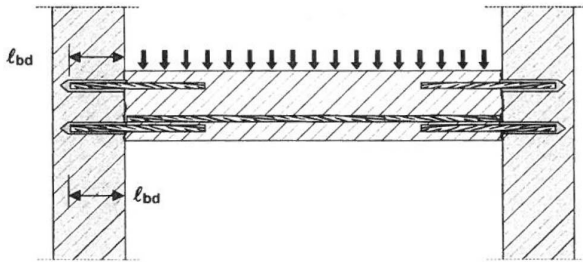

Figure A3 End anchoring of slabs or beams, designed as simply supported

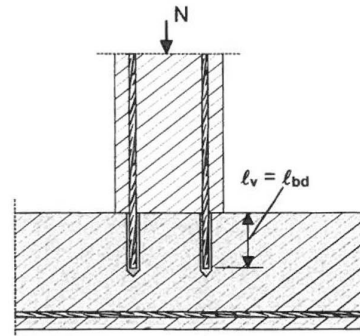
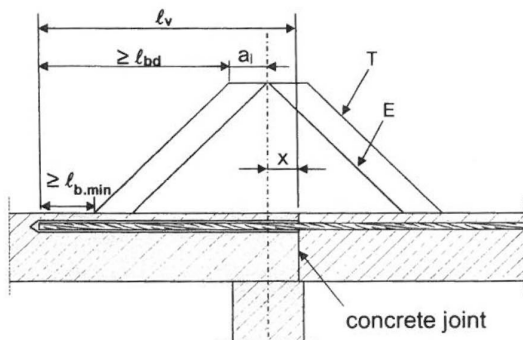

Figure A4 rebar connection for components stressed primarily in compression; rebar is stressed in compression



(only post-installed rebar is plotted)

Figure A5 Anchoring of reinforcement to cover the line of acting tensile force

Key to Figure A5

- T acting tensile force
- E envelope of $M_{ed}/z + N_{ed}$ (see EN 1992-1-1, Figure 9.2)
- x distance between the theoretical point of support and concrete joint

Note to Figure A1 to A5

In the Figures no transverse reinforcement is plotted, the transverse reinforcement as required by EN 1992-1-1 shall be present.

The shear transfer between old and new concrete shall be designed according to EN 1992-1-1.

Injection system R-KEX II for rebar connections

Product description
Use of the product

Annex A 1

Side by side cartridge - 385 to 1100 ml

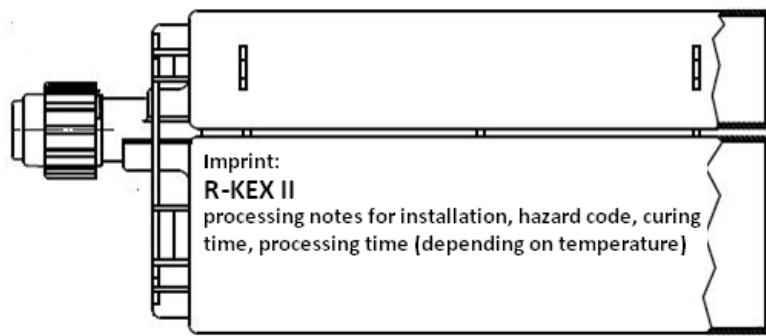

Mixer for cartridge

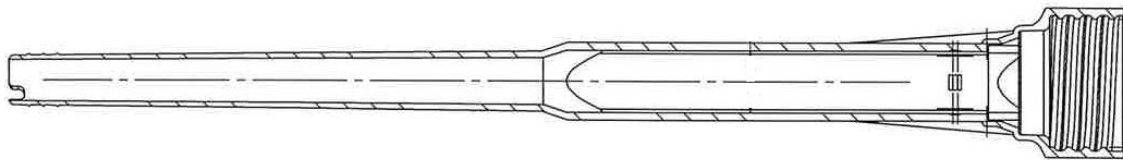

Mixer extension

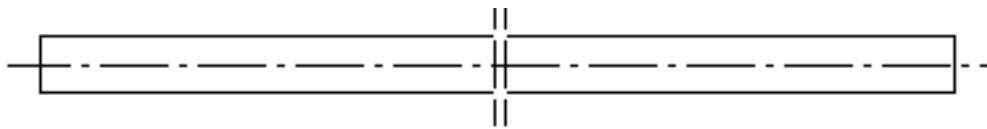

Reinforced bar (rebar)

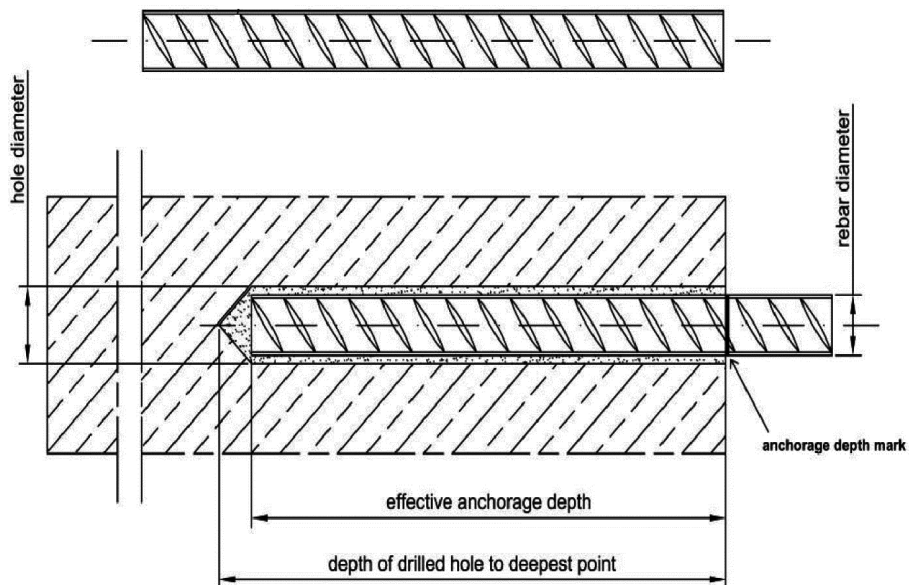

Injection system R-KEX II for rebar connections

Product description
Product description

Annex A 2

Table A1: Rebars

Designation	Rebars
Rebars according to EN 1992-1-1, Annex C, Table C.1 and C.2N	Bars and de-coiled rods: Class B or C Minimum relative rib area, $f_{R,min}$, according to EN 1992-1-1 The rib height h : $0.05 \cdot \varnothing \leq h \leq 0.07 \cdot \varnothing$

Table A2: Injection mortar

Designation	Composition
R-KEX II (two component injection mortar)	Injection mortar: epoxy system with fillers

Injection system R-KEX II for rebar connections**Product description**
Materials**Annex A 3**

SPECIFICATION OF INTENDED USE

Anchorage subject to:

Static and quasi-static loads.

Base material:

- Reinforced or unreinforced normal weight concrete of strength class C12/15 at minimum to C50/60 at maximum according to EN 206.
- Maximum chloride content of 0.40% (Cl 0.40) related to the cement content according to EN 206.
- Non-carbonated concrete.

Note: In the case of a carbonated surface of the existing concrete structure, the carbonate layer shall be removed in the area of the post-installed rebar connection with a diameter of $d_s + 60$ mm, prior to the installation of the new rebar. The depth of concrete to be removed shall correspond to at least the minimum concrete cover according to EN 1992-1-1.

The above may be ignored if building components are new and not carbonated and if they are in dry conditions.

Temperature in the base material:

At installation:

- +5°C to +30°C.

In service:

- -40°C to +80°C (max. short term temperature +80°C and max. long term temperature +50°C).

Use conditions (environmental conditions):

- Structures subject to dry internal conditions.
- Structures subject to external atmospheric exposure including industrial and marine environment.
- Structures subject to permanently damp internal conditions if no particular aggressive conditions exist.

Note: Particular aggressive conditions are e.g. permanent, alternating immersion in seawater or the splash zone of seawater, chloride atmosphere of indoor swimming pools or atmosphere with extreme chemical pollution (e.g. in desulphurization plants or road tunnels where de-icing materials are used).

Design:

- Anchorages are designed under the responsibility of an engineer experienced in anchorages and concrete work.
- Verifiable calculation notes and drawings are prepared taking into account the forces to be transmitted.
- Design according to EN 1992-1-1 and Annex B2.
- The actual position of the reinforcement in the existing structure shall be determined on the basis of the construction documentation, and taken into account when designing.

Installation:

- Dry or wet concrete (use category 1).
- It must not be installed in flooded holes.
- Overhead installation is permissible.
- Hole drilling by hammer drilling with or without hollow drill bit or diamond drilling.
- Installation of the post-installed rebar shall be done only by suitable trained installers and under supervision on the site.
- Check the position of the existing rebar (if the position of existing rebars is not known it shall be determined using a rebar detector suitable for this purpose as well as on the basis of the construction documentation, and then marked on the building component for the overlap joint).

Injection system R-KEX II for rebar connections

Intended use
Specification

Annex B 1

General design rules of construction for post-installed rebar

- Only tension forces in the axis of the rebar may be transmitted.
- The transfer of shear forces between new concrete and existing structure shall be designed additionally according to EN 1992-1-1.
- The joints for concreting must be roughened to at least such an extent that aggregates protrude.

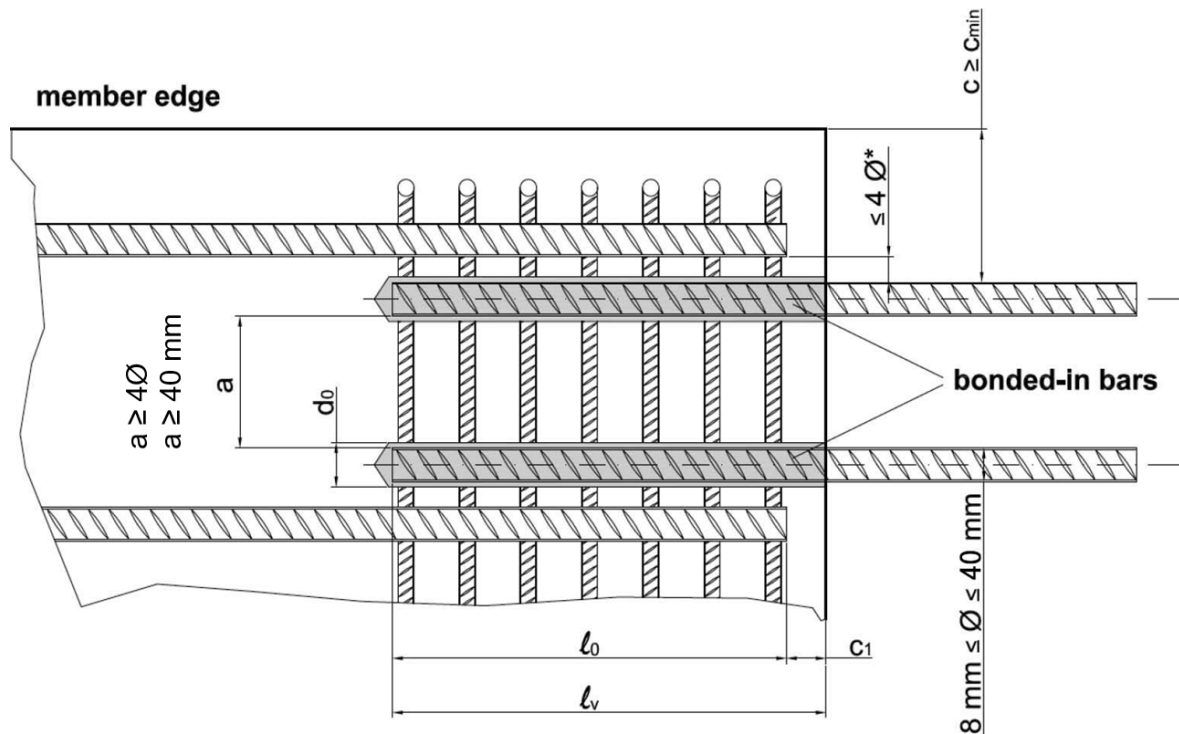

* If the clear distance between overlapping rebar is greater than $4 \cdot \emptyset$ the overlap length shall be enlarged by the difference between the clear distance and $4 \cdot \emptyset$.

- l_0 – lap length acc. to EN 1992-1-1, clause 8.7.3
- l_v – effective embedment depth; $l_v \geq l_0 + c_1$
- c – concrete cover of post-installed rebar
- c_{min} – minimum concrete cover acc. to Annex B3 and EN 1992-1-1, clause 4.4.1.2
- c_1 – concrete cover at end-face of existing rebar
- d_0 – nominal drill bit diameter acc. to Annex B3
- \emptyset – rebar diameter (d_s)

Injection system R-KEX II for rebar connections

Intended use

General construction rules for post-installed rebars

Annex B 2

Table B1: Installation data – hammer or diamond drilling – concrete C12/15

Rebar diameter [mm]	Ø8	Ø10	Ø12	Ø13	Ø14	Ø16	Ø18	Ø20
Drill bit diameter [mm]	12	14	16	16	18	20	22	25
Brush diameter [mm]	14	16	18	18	20	22	24	27
Minimum anchorage length $l_{b,min}$ [mm]	200	245	290	320	345	390	440	490
Minimum anchorage length $l_{v,min}$ - overlap joint [mm]	295	370	440	480	515	590	660	735
Maximum embedment depth $l_{v,max}$ [mm]	700	900	1000	1100	1200	1300	1500	1700

Rebar diameter [mm]	Ø22	Ø25	Ø28	Ø30	Ø32	Ø34	Ø36	Ø40
Drill bit diameter [mm]	26	30	35	35	40	45	45	50
Brush diameter [mm]	27	32	37	37	42	47	47	52
Minimum anchorage length $l_{b,min}$ [mm]	540	615	685	735	785	835	880	980
Minimum anchorage length $l_{o,min}$ - overlap joint [mm]	810	920	1030	1100	1175	1250	1320	1470
Maximum embedment depth $l_{v,max}$ [mm]	1800	2100	2300	2500	2000	2000	2000	2000

Note:

$l_{b,min}$ (or $l_{v,min}$) = $\alpha l_b \times \max \{0.3 \times l_{b,rqd}; 10\emptyset; 100 \text{ mm}\}$ for Ø8 to Ø40
 $l_{o,min}$ (or $l_{v,min}$) = $\alpha l_b \times \max \{0.3 \times \alpha_6 \times l_{b,rqd}; 15\emptyset; 200 \text{ mm}\}$ for Ø8 to Ø40
 with: yield stress for rebar 600 N·mm⁻²; $\gamma_M = 1.15$; $\alpha_6 = 1.5$;
 concrete C12/15 – $f_{bd} = 1.6 \text{ N}\cdot\text{mm}^{-2}$ (good bond conditions)

Minimum concrete cover (see Annex B2):

$c_{min} = 30 \text{ mm} + 0.06 \cdot l_v \geq 2\emptyset$

The minimum concrete cover according to EN 1992-1-1 shall be observed.

Minimum clear spacing between two post-installed rebar:

$a \geq 40 \text{ mm}$

$a \geq 4\emptyset$

Injection system R-KEX II for rebar connections

Intended use
 Installation data – hammer or diamond drilling

Annex B 3

Table B2: Installation data – hammer or diamond drilling – concrete C20/25

Rebar diameter [mm]	Ø8	Ø10	Ø12	Ø13		Ø14	Ø16	Ø18	Ø20
Drill bit diameter [mm]	12	14	16	16		18	20	22	25
Brush diameter [mm]	14	16	18	18		20	22	24	27
Minimum anchorage length $l_{b,min}$ [mm]	115	145	170	185		200	230	260	285
Minimum anchorage length $l_{v,min}$ - overlap joint [mm]	200	215	260	270		300	345	385	430
Maximum embedment depth $l_{v,max}$ [mm]	400	500	600	700		700	800	900	1000

Rebar diameter [mm]	Ø22	Ø25	Ø28	Ø30	Ø32	Ø34	Ø36	Ø40
Drill bit diameter [mm]	26	30	35	35	40	45	45	50
Brush diameter [mm]	27	32	37	37	42	47	47	52
Minimum anchorage length $l_{b,min}$ [mm]	315	355	400	420	455	485	510	570
Minimum anchorage length $l_{o,min}$ - overlap joint [mm]	470	535	600	640	690	725	770	855
Maximum embedment depth $l_{v,max}$ [mm]	1100	1200	1400	1500	2500	2000	2000	2000

Note:

$l_{b,min}$ (or $l_{v,min}$) = α_{lb} x max {0,3 x $l_{b,rqd}$; 10Ø; 100 mm} for Ø8 to Ø40

$l_{o,min}$ (or $l_{v,min}$) = α_{lb} x max {0,3 x α_6 x $l_{b,rqd}$; 15Ø; 200 mm} for Ø8 to Ø40

with: yield stress for rebar 500 N·mm⁻²; $\gamma_M = 1.15$; $\alpha_6 = 1.5$;

concrete C20/25 – $f_{bd} = 2.3$ N·mm⁻² (good bond conditions)

Minimum concrete cover (see Annex B2):

$$c_{min} = 30 \text{ mm} + 0.06 \cdot l_v \geq 2\text{Ø}$$

The minimum concrete cover according to EN 1992-1-1 shall be observed.

Minimum clear spacing between two post-installed rebar:

$$a \geq 40 \text{ mm}$$

$$a \geq 4\text{Ø}$$

Injection system R-KEX II for rebar connections

Intended use

Installation data – hammer or diamond drilling

Annex B 4

Table B3: Processing time and minimum curing time

R-KEX II			
Temperature of resin [°C]	Temperature of substrate [°C]	Processing time [min.]	Minimum curing time¹⁾ [min.]
+5	+5	150	2880
+10	+10	120	1080
+20	+20	35	480
+25	+30	12	300

1) The minimum time from the end of the mixing to the time when the rebar may be loaded. Minimum resin temperature for installation +5°C. Maximum resin temperature for installation +25°C. For wet condition the curing time must be doubled.

Injection system R-KEX II for rebar connections

Intended use
Processing time and curing time

Annex B 5

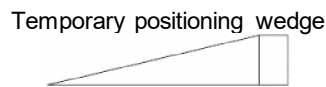
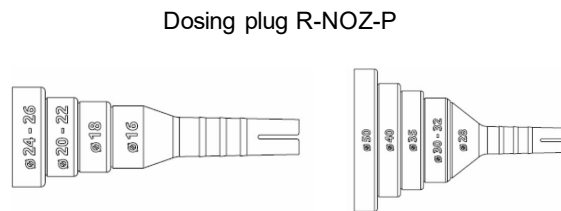
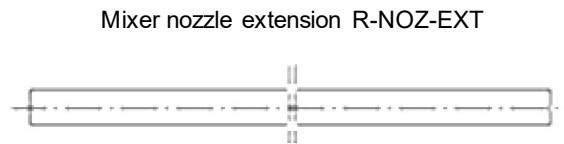
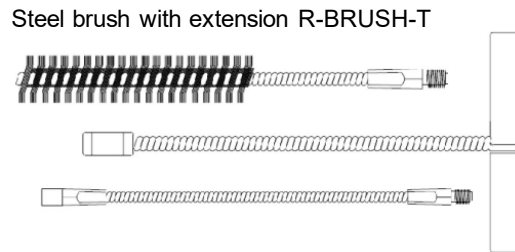
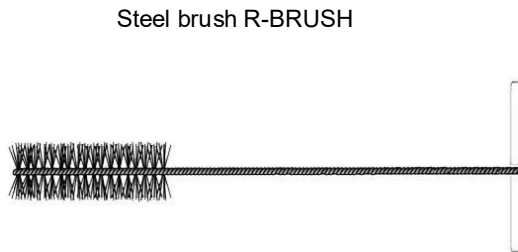
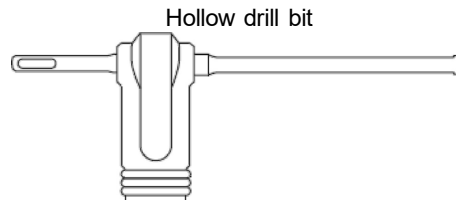
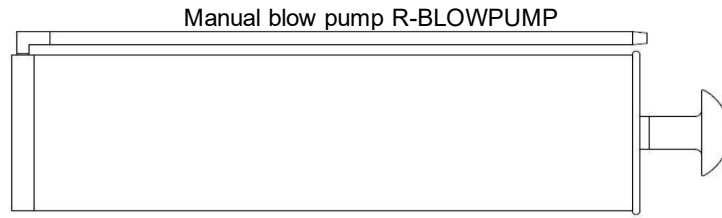

Table B4: Brushes for cleaning the drilled holes

Rebar diameter [mm]	Ø8	Ø10	Ø12	Ø13	Ø14	Ø16	Ø18	Ø20	Ø22	Ø25	Ø28	Ø30	Ø32	Ø34	Ø36	Ø40
Type of the brush	with steel wires															
Brush head diameter [mm]	14	16	18	18	20	22	24	27	27	32	37	37	42	47	47	52
Brush head length [mm]	80								100							

Injection system R-KEX II for rebar connections

Intended use
Tools for installation (1)



Annex B 6

Dispenser	Cartridge size
 <p data-bbox="327 533 959 568">Manual gun for side by side cartridges R-GUN-385-P</p>	385 ml
 <p data-bbox="327 846 959 882">Manual gun for side by side cartridges R-GUN-600-P</p>	385, 600 ml
 <p data-bbox="502 1227 783 1263">Cordless dispenser gun</p>  <p data-bbox="491 1653 799 1688">Pneumatic dispenser gun</p>	385, 600 ml

Injection system R-KEX II for rebar connections

Intended use
Tools for installation (2)

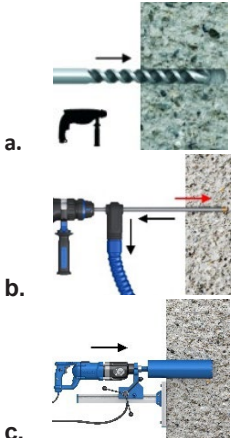
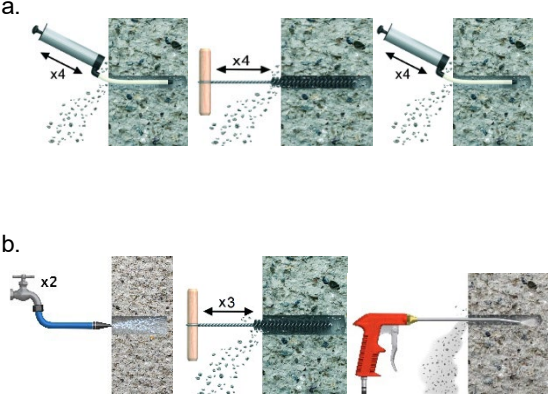
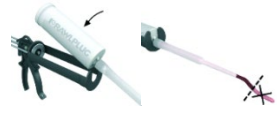
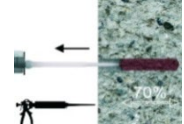
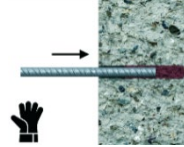
Annex B 7

	<p>1. Hole drilling:</p> <p>a. Hammer drilling.</p> <ol style="list-style-type: none"> 1. Drill hole to the required diameter and depth using a rotary hammer drilling machine. 2. Hammer drilling with hollow drill bit. <p>b. Hammer drilling with hollow drill bit.</p> <ol style="list-style-type: none"> 1. Drill hole to the required diameter and depth using a hollow drill bit with vacuum cleaner. After drilling is completed, proceed to step no. 3. Hole cleaning is not necessary. Hollow drill bit cleans the drill hole during drilling. <p>c. Diamond core drilling.</p> <ol style="list-style-type: none"> 3. Drill hole to the required diameter and depth using a diamond core drilling machine and the corresponding core bit.
	<p>2. Hole cleaning.</p> <p>a. Manual cleaning with brush and hand pump for hammer drilled hole:</p> <ul style="list-style-type: none"> – starting from the drill hole bottom blow the hole at least 4 times using the hand pump, – using the specified brush, mechanically brush out the hole at least 4 times, – starting from the drill hole bottom, blow at least 4 times with the hand pump. <p>b. Cleaning hole, diamond drilling, with compressed air:</p> <ul style="list-style-type: none"> – flush the hole from the bottom with water at least 2 times, – using the specified brush, mechanically brush out the hole at least 3 times, – starting from the drill hole bottom, blow at least 2 times with the pump.
	<p>3. Insert cartridge into dispenser and attach nozzle. Dispense to waste until even colour is obtained (min. 10 cm).</p>
	<p>4. Insert the mixing nozzle to the far end of the hole and inject resin, slowly withdrawing the nozzle as the hole is filled to 2/3 of its depth.</p>
	<p>5. Immediately insert the rebar, slowly and with slight twisting motion. Remove any excess resin around the hole before it sets.</p>
	<p>6. Leave the fixing undisturbed until the curing time elapses.</p>

Injection system R-KEX II for rebar connections

Intended use
Installation instruction (1)

Annex B 8



	<p>1. Inject from the bottom of the hole. Inject the product about 2/3 of the hole depth. For the best performance use extension and appropriately sized piston plug assembled on the mixer.</p>
	<p>2. Drive the rebar immediately into the hole. Use temporary interlocking element e.g wedges.</p>
	<p>3. Leave the fixing undisturbed until the curing time elapses. To avoid the slipping of the rebar during the open time of the product (due to the rebar own weight) use a temporary interlocking element.</p>

Table B5. Piston plug R-NOZ-P size

Hole diameter [mm]	16	18	20	22	25	26	28	30	35	40	45	50
Piston plug R-NOZ-P description	Ø16	Ø18	Ø 20-22		Ø24-26		Ø28	Ø30-32	Ø35	Ø40		Ø50

Injection system R-KEX II for rebar connections

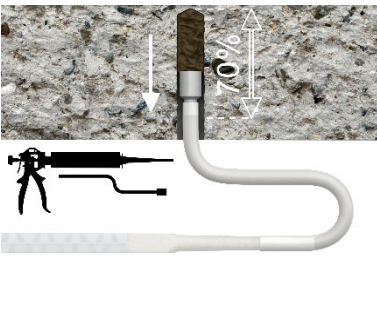
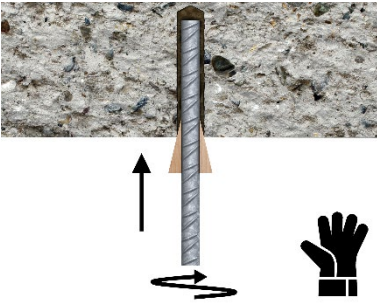
Intended use
Installation instruction (2)

Annex B 9

Table C1: Amplification factor α_{lb}

The minimum anchorage length $l_{b,min}$ and the minimum lap length $l_{o,min}$ according to EN 1992-1-1 shall be multiplied by the relevant amplification factor α_{lb} in table C1.

Rebar diameter [mm]	Concrete strength class								
	C12/15	C16/20	C20/25	C25/30	C30/37	C35/45	C40/50	C45/55	C50/60
Ø8	1	1	1	1	1	1	1	1	1
Ø10	1	1	1	1	1	1	1	1	1
Ø12	1	1	1	1	1	1	1	1	1
Ø13	1	1	1	1	1	1	1	1	1
Ø14	1	1	1	1	1	1	1	1	1
Ø16	1	1	1	1	1	1	1	1	1
Ø18	1	1	1	1	1	1	1	1	1
Ø20	1	1	1	1	1	1	1	1	1
Ø22	1	1	1	1	1	1	1	1	1
Ø25	1	1	1	1	1	1	1	1	1
Ø28	1	1	1	1	1	1	1	1	1
Ø30	1	1	1	1	1	1	1	1	1
Ø32	1	1	1	1	1	1	1	1	1
Ø34	1	1	1	1	1	1	1	1	1
Ø36	1	1	1	1	1	1	1	1	1
Ø40	1	1	1	1	1	1	1	1	1

Injection system R-KEX II for rebar connections

Performance
Amplification factor α_{lb}

Annex C 1

Table C2: Bond efficiency value k_b for hammer drilling

Rear diameter [mm]	Concrete strength class								
	C12/15	C16/20	C20/25	C25/30	C30/37	C35/45	C40/50	C45/55	C50/60
Ø8	1	1	1	1	1	1	1	1	1
Ø10	1	1	1	1	1	1	1	1	1
Ø12	1	1	1	1	1	1	1	1	1
Ø13	1	1	1	1	1	1	1	1	1
Ø14	1	1	1	1	1	1	1	1	1
Ø16	1	1	1	1	1	1	1	1	0.93
Ø18	1	1	1	1	1	1	1	1	0.93
Ø20	1	1	1	1	1	1	1	0.92	0.86
Ø22	1	1	1	1	1	1	1	0.92	0.86
Ø25	1	1	1	1	1	1	0.91	0.84	0.79
Ø28	1	1	1	1	1	1	0.91	0.84	0.79
Ø30	1	1	1	1	1	0.90	0.82	0.76	0.71
Ø32	1	1	1	1	1	0.90	0.82	0.76	0.71
Ø34	1	1	1	1	0.89	0.80	0.73	0.67	0.63
Ø36	1	1	1	0.86	0.76	0.69	0.63	0.58	0.54
Ø40	1	1	1	0.86	0.76	0.69	0.63	0.58	0.54

Injection system R-KEX II for rebar connections

Performance
Bond efficiency value k_b for hammer drilling

Annex C 2

Table C3: Bond efficiency value k_b for diamond drilling

Rear diameter [mm]	Concrete strength class								
	C12/15	C16/20	C20/25	C25/30	C30/37	C35/45	C40/50	C45/55	C50/60
Ø8	1	1	1	1	1	1	1	1	1
Ø10	1	1	1	1	1	1	1	1	1
Ø12	1	1	1	1	1	1	1	1	1
Ø13	1	1	1	1	1	1	1	1	1
Ø14	1	1	1	1	1	1	1	1	0.93
Ø16	1	1	1	1	1	1	1	1	0.93
Ø18	1	1	1	1	1	1	1	1	0.93
Ø20	1	1	1	1	1	1	1	0.92	0.86
Ø22	1	1	1	1	1	1	1	0.92	0.86
Ø25	1	1	1	1	1	1	0.91	0.84	0.79
Ø28	1	1	1	1	1	0.90	0.82	0.76	0.71
Ø30	1	1	1	1	0.89	0.80	0.73	0.67	0.63
Ø32	1	1	1	1	0.89	0.80	0.73	0.67	0.63
Ø34	1	1	1	1	0.89	0.80	0.73	0.67	0.63
Ø36	1	1	1	0.86	0.76	0.69	0.63	0.58	0.54
Ø40	1	1	0.86	0.74	0.66	0.59	0.54	0.50	0.47

Injection system R-KEX II for rebar connections

Performance
Bond efficiency value k_b for diamond drilling

Annex C 3

Table C4: Design values of the ultimate bond resistance $f_{bd}^{(1)}$ in N·mm⁻² for hammer drilling

Rebar diameter [mm]	Concrete strength class								
	C12/15	C16/20	20/25	C25/30	C30/37	C35/45	C40/50	C45/55	C50/60
Ø8	1.60	2.00	2.30	2.70	3.00	3.40	3.70	4.00	4.30
Ø10	1.60	2.00	2.30	2.70	3.00	3.40	3.70	4.00	4.30
Ø12	1.60	2.00	2.30	2.70	3.00	3.40	3.70	4.00	4.30
Ø13	1.60	2.00	2.30	2.70	3.00	3.40	3.70	4.00	4.30
Ø14	1.60	2.00	2.30	2.70	3.00	3.40	3.70	4.00	4.30
Ø16	1.60	2.00	2.30	2.70	3.00	3.40	3.70	4.00	4.00
Ø18	1.60	2.00	2.30	2.70	3.00	3.40	3.70	4.00	4.00
Ø20	1.60	2.00	2.30	2.70	3.00	3.40	3.70	3.70	3.70
Ø22	1.60	2.00	2.30	2.70	3.00	3.40	3.70	3.70	3.70
Ø25	1.60	2.00	2.30	2.70	3.00	3.40	3.40	3.40	3.40
Ø28	1.60	2.00	2.30	2.70	3.00	3.40	3.40	3.40	3.40
Ø30	1.60	2.00	2.30	2.70	3.00	3.00	3.00	3.00	3.00
Ø32	1.60	2.00	2.30	2.70	3.00	3.00	3.00	3.00	3.00
Ø34	1.60	2.00	2.30	2.70	2.70	2.70	2.70	2.70	2.70
Ø36	1.60	2.00	2.30	2.30	2.30	2.30	2.30	2.30	2.30
Ø40	1.60	2.00	2.00	2.00	2.00	2.00	2.00	2.00	2.00

¹⁾ According to EN 1992-1-1 for good bond conditions.
For all other bond conditions multiply the value by 0.7.

Injection system R-KEX II for rebar connections

Performance

Design values of the ultimate bond resistance f_{bd}
for hammer drilling

Annex C 4

Table C5: Design values of the ultimate bond resistance $f_{bd}^{(1)}$ in $N \cdot mm^{-2}$ for diamond drilling

Rebar diameter [mm]	Concrete strength class								
	C12/15	C16/20	20/25	C25/30	C30/37	C35/45	C40/50	C45/55	C50/60
Ø8	1.60	2.00	2.30	2.70	3.00	3.40	3.70	4.00	4.30
Ø10	1.60	2.00	2.30	2.70	3.00	3.40	3.70	4.00	4.30
Ø12	1.60	2.00	2.30	2.70	3.00	3.40	3.70	4.00	4.30
Ø13	1.60	2.00	2.30	2.70	3.00	3.40	3.70	4.00	4.30
Ø14	1.60	2.00	2.30	2.70	3.00	3.40	3.70	4.00	4.00
Ø16	1.60	2.00	2.30	2.70	3.00	3.40	3.70	4.00	4.00
Ø18	1.60	2.00	2.30	2.70	3.00	3.40	3.70	4.00	4.00
Ø20	1.60	2.00	2.30	2.70	3.00	3.40	3.70	3.70	3.70
Ø22	1.60	2.00	2.30	2.70	3.00	3.40	3.70	3.70	3.70
Ø25	1.60	2.00	2.30	2.70	3.00	3.40	3.40	3.40	3.40
Ø28	1.60	2.00	2.30	2.70	3.00	3.00	3.00	3.00	3.00
Ø30	1.60	2.00	2.30	2.70	3.00	2.70	2.70	2.70	2.70
Ø32	1.60	2.00	2.30	2.70	3.00	2.70	2.70	2.70	2.70
Ø34	1.60	2.00	2.30	2.70	2.70	2.70	2.70	2.70	2.70
Ø36	1.60	2.00	2.30	2.30	2.30	2.30	2.30	2.30	2.30
Ø40	1.60	2.00	2.00	2.00	2.00	2.00	2.00	2.00	2.00

¹⁾ According to EN 1992-1-1 for good bond conditions.
For all other bond conditions multiply the value by 0.7.

Injection system R-KEX II for rebar connections

Performance

Design values of the ultimate bond resistance f_{bd} for diamond drilling

Annex C 5



British Board of Agrément,
Bucknalls Lane,
Watford,
Hertfordshire
WD25 9BA